

SECTION B-B SECTION A-A

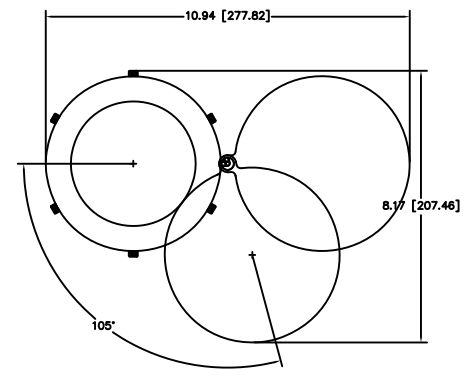

MINIMUM SHUTTER SWING CLEARANCE