

- NOTES: UNLESS OTHERWISE SPECIFIED
- INTERPRET DRAWING IAW THE GLOBAL PROFESSIONAL PUBLICATIONS "DRAWING REQUIREMENTS MANUAL", EIGHTH EDITION.
 - INTERPRET DIMENSIONS AND TOLERANCES IAW ANSI Y14.5M - 1982.
 - INTERPRET ABBREVIATIONS IAW MIL-STD-12.
- ⚠ GAS FITTING (INCLUDED), SWAGelok (ITEM 9) IS AVAILABLE FROM: [HTTP://WWW.SWAGelok.COM](http://www.swagelok.com)
 - ⚠ MINIMUM 60" LONG POLYETHYLENE LINES REQUIRED FOR SAFE OPERATION. USER MUST SUPPLY ADDITIONAL 42" LONG POLYETHYLENE WATER LINES TO MEET THIS REQUIREMENT. DO NOT SUBSTITUTE METAL WATER FITTINGS FOR ITEM 8.
 - ⚠ WATER LINE CONNECTORS (INCLUDED, ITEM 8) ARE AVAILABLE FROM: [HTTP://WWW.JOHNGUEST.COM](http://www.johnguest.com)
 - ⚠ MINIMUM 36" LONG TEFLON PFA LINE REQUIRED (36" INCLUDED WITH SOURCE) FOR SAFE OPERATION. DO NOT USE METAL GAS LINES TO MEET THIS REQUIREMENT - ELECTRICAL ISOLATION IS NECESSARY.
- SEE MATERIALS SCIENCE, INC. DOCUMENT NO. 251011 FOR PROPER INSTALLATION, OPERATION AND USE OF POLARIS SPUTTERING SOURCES.

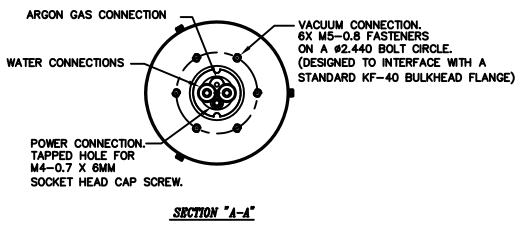
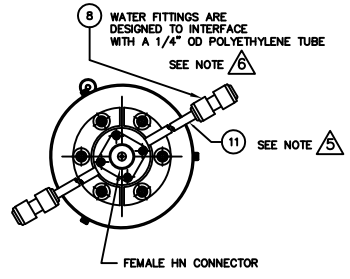
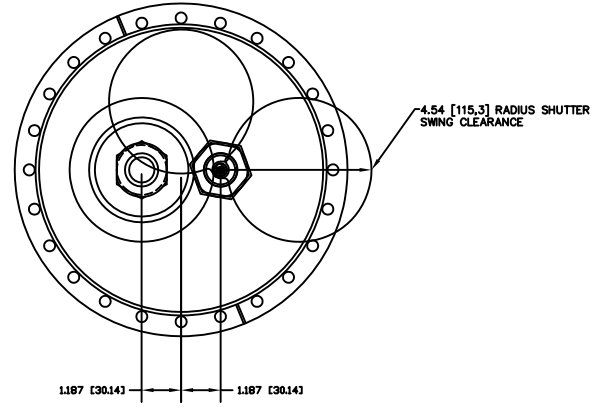
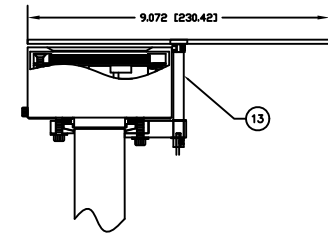
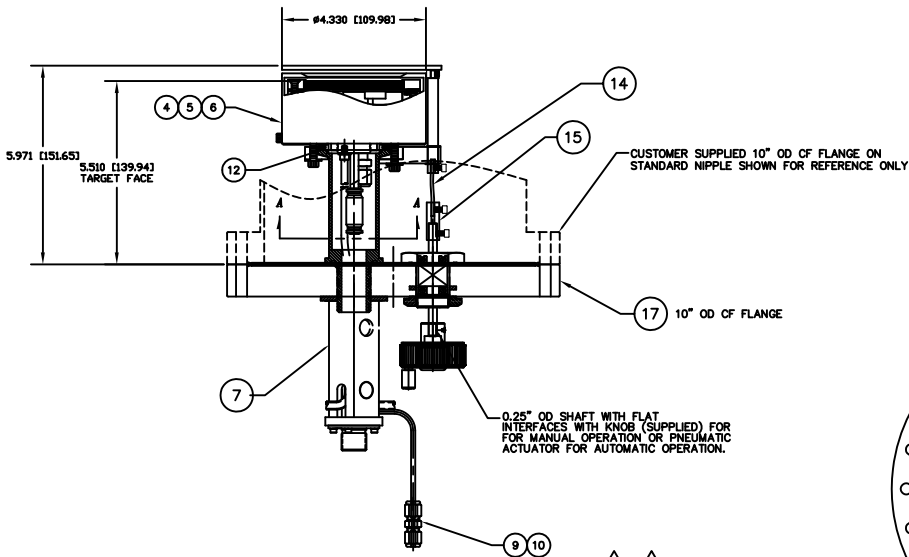

QTY	UNIT	DESCRIPTION	MATERIAL SPECIFICATION	ZONE	ITEM NO			
1	1	1	00003049	10 INCH OF FLANGE, MODIFIED, 2 1" DIA. HOLES	304 CRES	18		
1	1	1	00002132	FEEDTHROUGH, ROTARY, FERROFLUID SEAL		17		
1	1	1	00002245	FEEDTHROUGH SHAFT CABLE CONNECTOR	304 CRES	16		
1	1	1	00002134	FLEXIBLE CABLE ASSEMBLY, 0.125" OD	304 CRES	15		
1	1	1	00000939	SHUTTER ASSEMBLY, 3 INCH POLARIS	304 CRES	14		
3	3	3	00000100-3	CENTERING RING, KF-40		13		
1	1	1	⚠ 00000074-1	TUBING, 1/4" OD X .170" ID X 18"	POLYETHYLENE	12		
1	1	1	⚠ 00000038-1	TUBING, 1/8" OD X 1/16" ID X 36" MINIMUM	TEFLON PFA	11		
1	1	1	⚠ 00000316	FITTING, SWAGelok, SS-200-6	316 CRES	10		
2	2	2	00000281-1	1/4 INCH OD COUPLING, QUICK CONNECT	P/N C1040BW	9		
1	1	1	00000787	RF/DC FEEDTHROUGH ASSEMBLY		8		
1	1	1	00002085-3	3 INCH INTERNAL CATHODE (CLAMPED TARGET)		7		
1	1	1	00002085-2	3 INCH INT CATHODE (DIRECT WATER COOLED TGT)		6		
1	1	1	00002085-1	3 INCH INTERNAL CATHODE (BONDED TARGET)		5		
1	1	1	00000719-3	3" POLARIS, KF-40/1" BASEPLATE FEEDTHROUGH		4		
1	1	1	00000719-2	3" POLARIS, KF-40/1" BASEPLATE FEEDTHROUGH		3		
1	1	1	00000719-1	3" POLARIS, KF-40/1" BASEPLATE FEEDTHROUGH		2		
-3	-2	-1	CASE CODE	PART OR IDENTIFYING NO.	NOMENCLATURE OR DESCRIPTION	MATERIAL SPECIFICATION	ZONE	ITEM NO

APPROVED: J. MILLER 10/00/00

DATE: 10/00/00

00003048

3" POLARIS, FIXED POSITION WITH SHUTTER - 10" CF FLANGE

1/1

INSTALLATION CONTROL DRAWING