

4

3

2

1

NOTES: UNLESS OTHERWISE SPECIFIED

- 1. INTERPRET DRAWING IAW THE GLOBAL PROFESSIONAL PUBLICATIONS "DRAWING REQUIREMENTS MANUAL", EIGHTH EDITION.
- 2. INTERPRET DIMENSIONS AND TOLERANCES IAW ANSI Y14.5M - 1982.
- 3. REMOVE ALL BURRS, SHARP EDGES, NICKS, AND SCRATCHES.
- 4. INTERPRET ABBREVIATIONS IAW MIL-STD-12.
- 5. DIMENSIONS IN BRACKETS "[ ]" DENOTE REFERENCE DIMENSIONS IN MILLIMETERS.

△ 6 MATERIAL:  
TO BE SPECIFIED BY CUSTOMER PRIOR TO FABRICATION.

- 7. FOR FURTHER FABRICATION REQUIREMENTS, SEE MATERIALS SCIENCE, INC. SPECIFICATION NO. 10000000.

REVISION				
ZONE	REV	DESCRIPTION	DATE	APPROVED
	-	INITIAL RELEASE	970107	
	A	ADDED -2 & -3	050405	J.MILLER

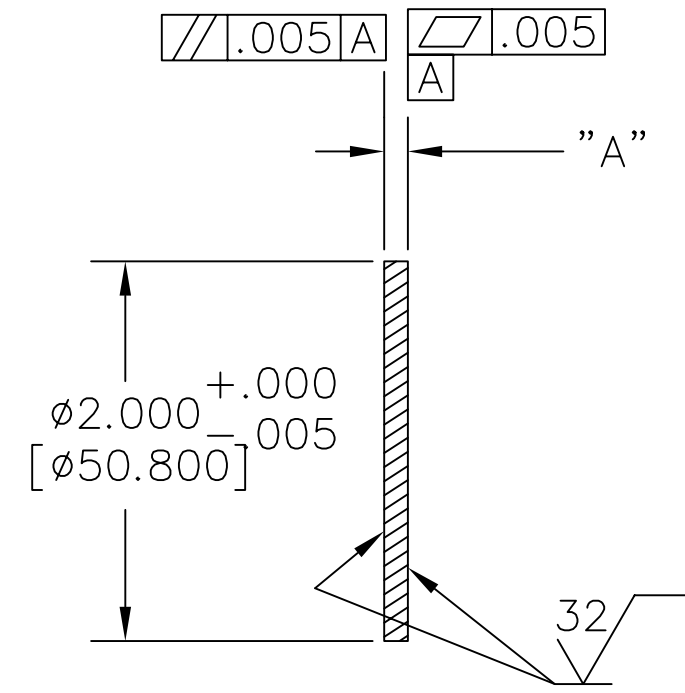

-1 DETAIL

DASH NO	DIM A
-1	.125 [3.175]
-2	.188 [4.775]
-3	.250 [6.350]

1				00000073-3	2 INCH TARGET	△ 6		1
	1			00000073-2	2 INCH TARGET	△ 6		1
		1		00000073-1	2 INCH TARGET	△ 6		1
-3	-2	-1	CAGE CODE	PART OR IDENTIFYING NO.	NOMENCLATURE OR DESCRIPTION	MATERIAL SPECIFICATION	ZONE	ITEM NO.

QUANTITY PER ASSEMBLY		PARTS LIST				DRAWN		APPROVAL		MATERIALS SCIENCE, INC.	
						C. CERVANTES	97/01/07			Vacuum and Thin Film Technology 1665 Lee Hill Road, San Diego, CA 92109	
										2 INCH TARGET	
										SIZE	REV
										C	A
										00000073	
										SCALE: 1/1	WT:
										DISP:	SHEET: 1 OF 1

DWG NO. 00000073 REV A

4

3

2

1