

NOTES: UNLESS OTHERWISE SPECIFIED

1. INTERPRET DIMENSIONS AND TOLERANCING IAW ANSI Y14.5M - 1982.
2. BREAK SHARP EDGES .002-.015.
3. INTERPRET ABBREVIATIONS IAW MIL-STD-12.

ZONE		REV	DESCRIPTION	DATE	APPROVED
		-	INITIAL RELEASE	050418	

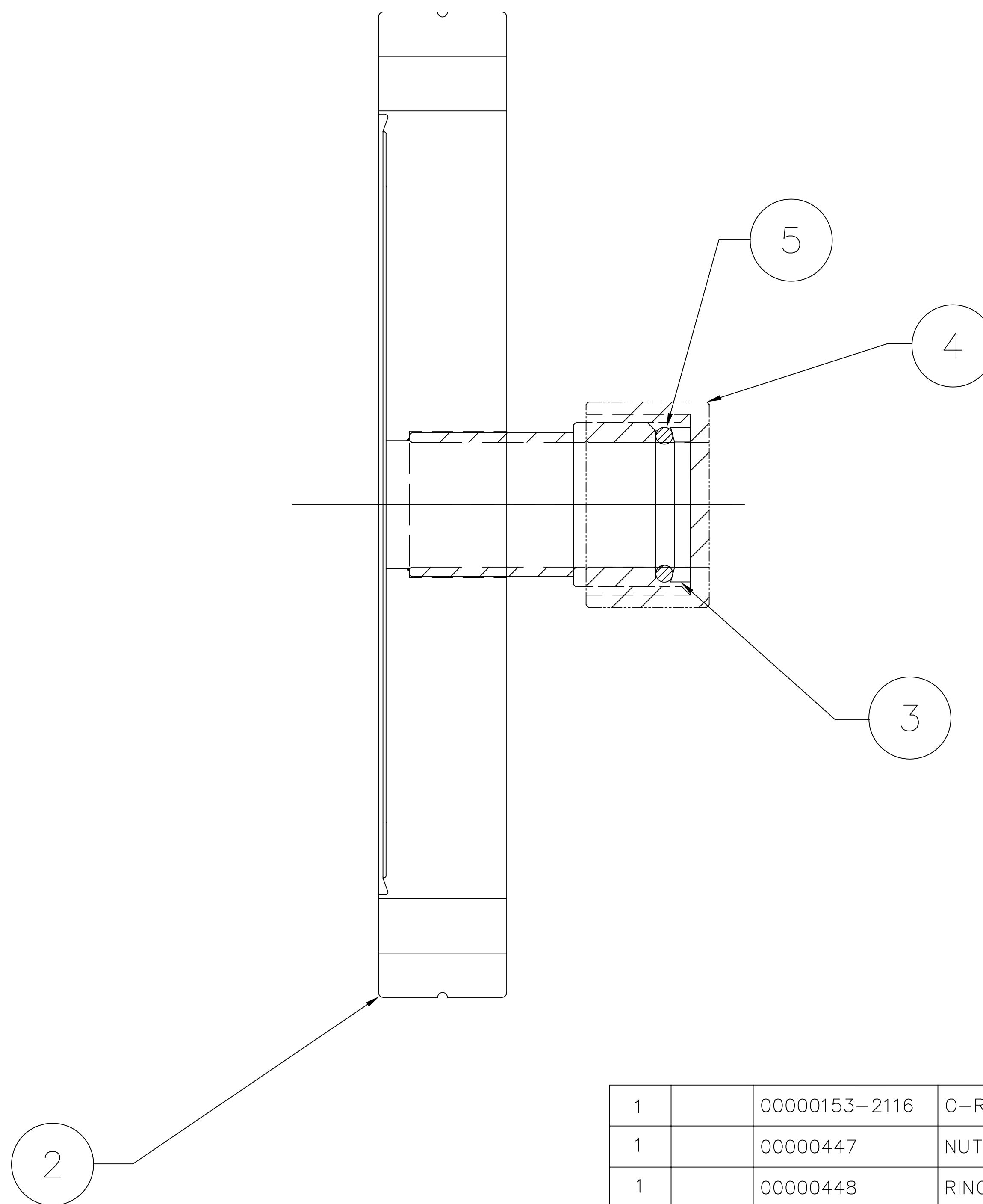

QUANTITY PER ASSEMBLY	CAGE CODE	PART OR IDENTIFYING NO.	NOMENCLATURE OR DESCRIPTION	MATERIAL SPECIFICATION	ZONE	ITEM NO
1		00000153-2116	O-RING, 75 DUROMETER 2-116	VITON		5
1		00000447	NUT, KNURLED	18-8 CRES		4
1		00000448	RING, RETENTION, 3/4" FEEDTHROUGH	18-8 CRES		3
1		00000453	WELDMENT, 6" OD CF FLG	18-8 CRES		2
		00000451	ADAPTOR ASSY, 6" OD CF FLG TO 3/4" OD TUBE			1

UNLESS OTHERWISE SPECIFIED DIMENSIONS ARE IN INCHES TOLERANCES ARE:		DRAWN J. MILLER 05/04/18	MATERIALS SCIENCE, INC. Vacuum and Thin Film Technology http://www.msi-pse.com	
DECIMALS .X ±.030 .XX ±.010 .XXX ±.005 ANGLES ±0°30'		APPROVAL - -		
MACHINE SURFACES UNLESS OTHERWISE SPECIFIED		FINISH	ADAPTOR ASSEMBLY, 6" O.D CF FLANGE TO 3/4" OD TUBE	
NEXT ASSEMBLY		USED ON	SIZE D	CAGE CODE
APPLICATION		DO NOT SCALE DRAWING	DWG. NO. 00000451	REV -
			SCALE: 1/1	WT:
			DISP:	SHEET: 1 OF 1

DWG. NO. 00000451 REV. -