

ZONE		REV	DESCRIPTION	DATE	APPROVED
		-	INITIAL RELEASE	961104	
A			CHANGED GAS & WATER FITTINGS	05/04/03	J. MILLER

NOTES: UNLESS OTHERWISE SPECIFIED

- INTERPRET DRAWING IAW THE GLOBAL PROFESSIONAL PUBLICATIONS "DRAWING REQUIREMENTS MANUAL", EIGHTH EDITION.
- INTERPRET DIMENSIONS AND TOLERANCES IAW ANSI Y14.5M - 1982.
- BREAK SHARP EDGES .002-015.
- INTERPRET ABBREVIATIONS IAW MIL-STD-12.
- DIMENSIONS IN BRACKETS "[ ]" DENOTE REFERENCE DIMENSIONS IN MILLIMETERS.
- LENGTH OF POWER CENTER CONDUCTOR CABLE ASSY (PART OF ITEM 4) IS FOR A STANDARD 1 1/2" BASEPLATE/CHAMBER WALL CONFIGURATION. PLEASE SPECIFY CHAMBER WALL THICKNESS WHEN ORDERING TO INSURE PROPER CABLE LENGTH AT TIME OF ASSY.
- GAS FITTING, SWAGELOK (ITEM 9) IS AVAILABLE FROM: [HTTP://WWW.SWAGELOK.COM](http://www.swagelok.com)
- MINIMUM 60" LONG POLYETHYLENE LINES REQUIRED FOR SAFE OPERATION. USER MUST SUPPLY ADDITIONAL 42" LONG POLYETHYLENE WATER LINES TO MEET THIS REQUIREMENT. DO NOT SUBSTITUTE METAL WATER FITTINGS FOR ITEM 8.
- WATER LINE CONNECTORS, (ITEM 8) ARE AVAILABLE FROM: [HTTP://WWW.JOHNQUEST.COM](http://www.johnguest.com)
- SEE MATERIALS SCIENCE, INC. DOCUMENT NO. 251010 FOR PROPER INSTALLATION, OPERATION AND USE OF POLARIS SPUTTERING SOURCES.
- MASS OF SPUTTERING SOURCE FULLY ASSEMBLED IS 5 LBS., DRY.

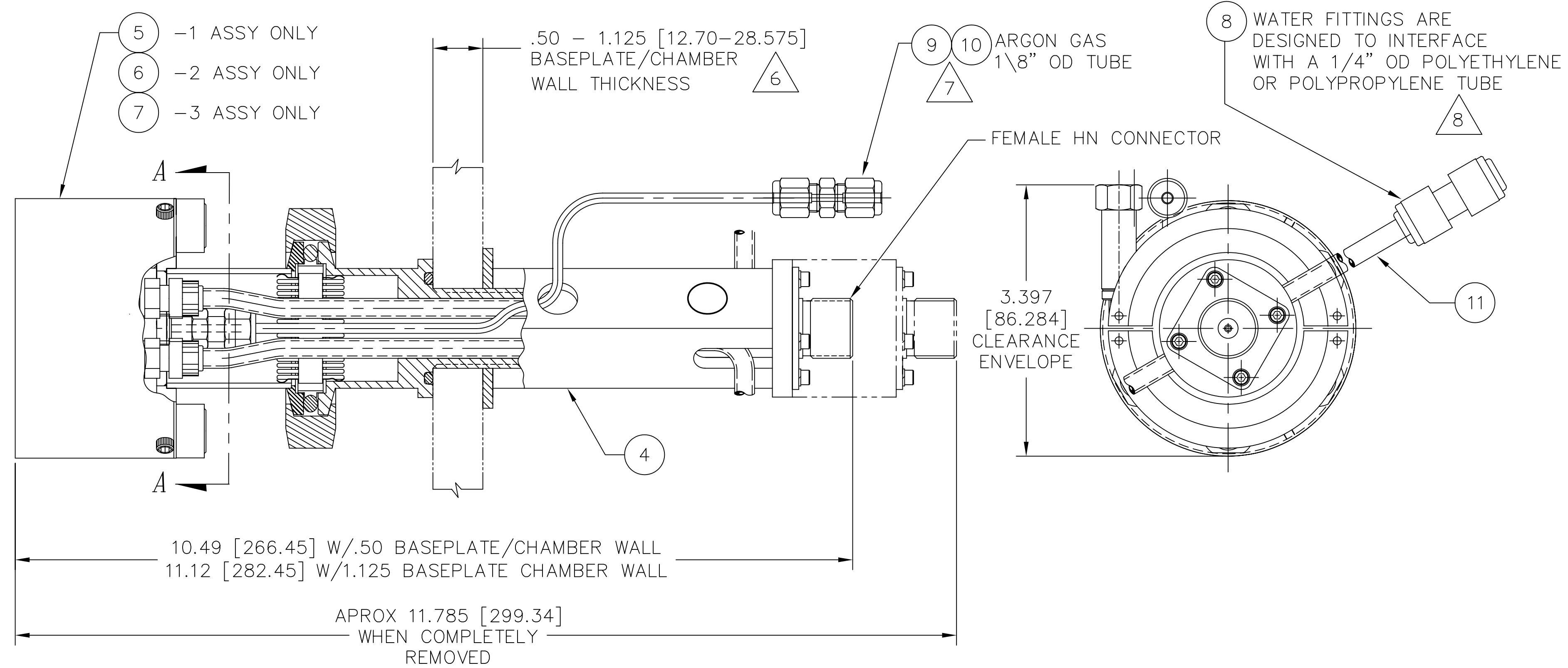

-1, -2, AND -3 ASSY SHOWN

QTY	QTY PER ASSEMBLY	QTY PER ASSEMBLY	QTY PER ASSEMBLY	CAGE CODE	PART OR IDENTIFYING NO.	NOMENCLATURE OR DESCRIPTION	MATERIAL SPECIFICATION	ZONE	ITEM NO
1	1	1	8		00000074-1	TUBING, 1/4" OD X .170" ID X 18"	POLYETHYLENE		11
1	1	1			00000038-1	TUBING, 1/8" OD X 1/16" ID X 36" MINIMUM	TEFLON PFA		10
1	1	1	7		00000316	FITTING, SWAGELOK, SS-200-6	316 CRES		9
2	2	2	9		00000281-1	1/4 INCH OD COUPLING, QUICK CONNECT	P/N CI0408W		8
1					00000055-3	2 INCH INTERNAL CATHODE ASSY			7
	1				00000055-2	2 INCH INTERNAL CATHODE ASSY			6
		1			00000055-1	2 INCH INTERNAL CATHODE ASSY			5
1	1	1			00000017-1	RF FEEDTHROUGH ASSY, QUICK CLAMP			4
					00000049-3	2 INCH INTERNAL CATHODE (CLAMPED TARGET)			3
					00000049-2	2 INCH INT CATHODE (DIRECT WATER COOLED TGT)			2
					00000049-1	2 INCH INTERNAL CATHODE (BONDED TARGET)			1

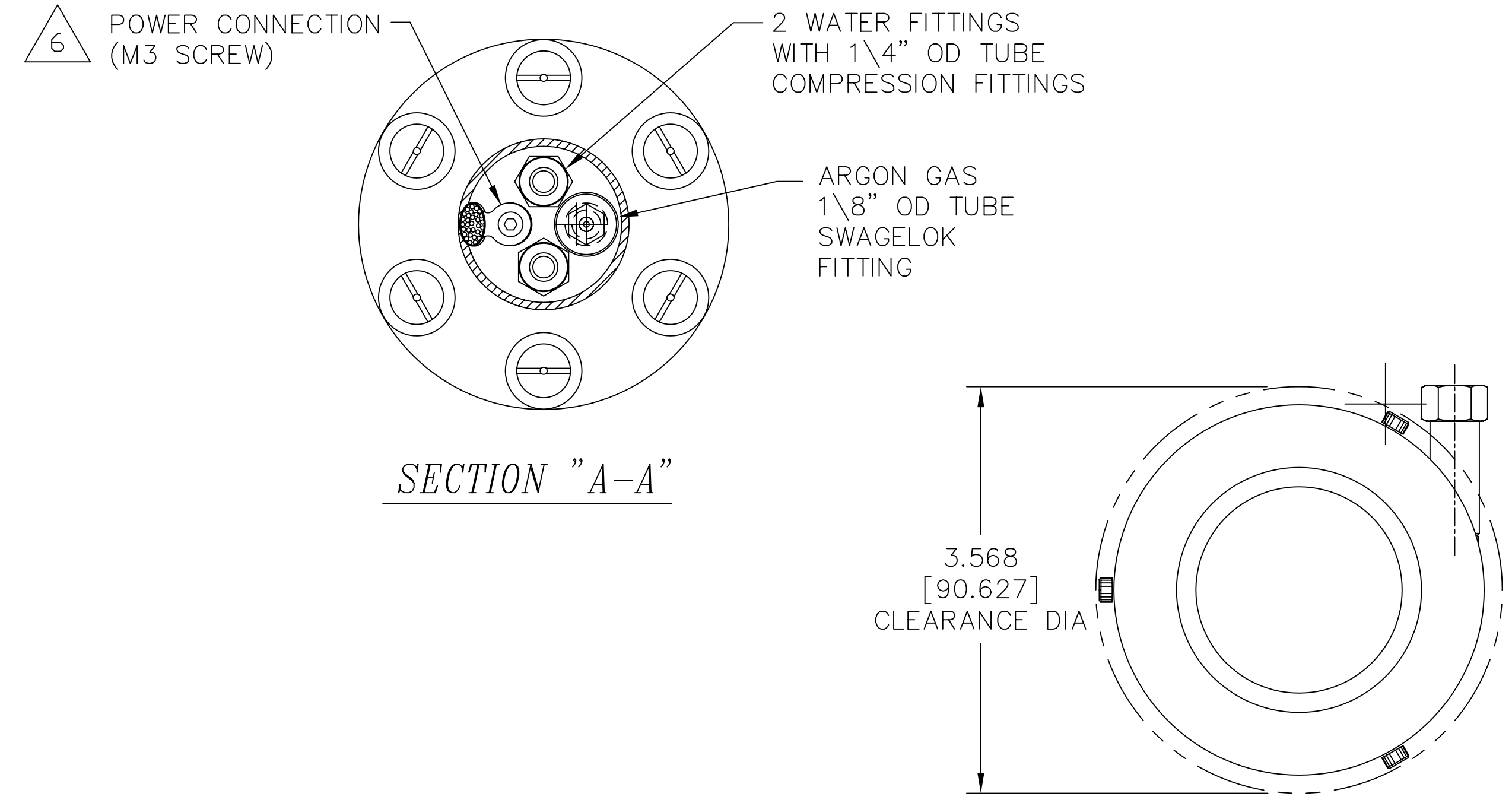

INSTALLATION CONTROL DRAWING

NEXT ASSEMBLY		USED ON		APPLICATION		DO NOT SCALE DRAWING	

UNLESS OTHERWISE SPECIFIED DIMENSIONS ARE IN INCHES TOLERANCES ARE:		DRAWN: G. CERVANTES 96/11/01		APPROVAL: -		MATERIALS SCIENCE, INC. Vacuum and Thin Film Technology <a href="http://www.msi-pse.com">HTTP://WWW.MSI-PSE.COM</a>	
DECIMALS .X ± .030	ANGLES ± 0°30'	THIS DRAWING CONTAINS PROPRIETARY INFORMATION AND ANY REPRODUCTION, DISCLOSURE OR USE OF THIS DRAWING WITHOUT WRITTEN PERMISSION FROM MATERIALS SCIENCE, INC. IS EXPRESSLY PROHIBITED.		2 INCH INT CATHODE, 1" BASE-PLATE RF/DC FEEDTHROUGH		SIZE: D	CAGE CODE: 00000049
MACHINE SURFACES UNLESS OTHERWISE SPECIFIED 125	FINISH	SCALE: 1/1	WT:	DISP:	SHEET: 1 OF 1	REV: A	