

- NOTES: UNLESS OTHERWISE SPECIFIED
- INTERPRET DRAWING IAW THE GLOBAL PROFESSIONAL PUBLICATIONS "DRAWING REQUIREMENTS MANUAL", EIGHTH EDITION.
 - INTERPRET DIMENSIONS AND TOLERANCES IAW ANSI Y14.5M - 1982.
 - INTERPRET ABBREVIATIONS IAW MIL-STD-12.

WARNING:
WATER FITTINGS HAVE A CLEAR ID OF .375 INCHES. USING A SLEEVE OR SIMILAR DEVICE INSIDE THE WATER HOSE MAY CAUSE FLUID RESTRICTIONS AND INTERFERENCE WITH THE NORMAL OPERATION OF THE CATHODE AND THEREFORE IS NOT RECOMMENDED.

WARNING:
WATER CHANNELS ARE SYMMETRICAL THROUGHOUT. ORIENTATION OF WATER INLET OR OUTLET IS NOT CRITICAL.

WARNING:
MINIMUM HOSE LENGTH OF 60" IS REQUIRED TO ENSURE RESISTIVITY RELATIVE TO ELECTRICAL GROUND WITHIN 50 KILO OHMS. TEST CABLE WITH AN OHM METER OR OTHER SUITABLE DEVICE BEFORE USE. DO NOT USE METAL TUBING! POLYETHYLENE RECOMMENDED.

WARNING:
SWAGelok UNION FITTING, 1/8" OD TUBE IS SUPPLIED WITH SOURCE SEE NOTE 13 AND ALSO AVAILABLE FROM SWAGelok COMPANY HTTP://WWW.SWAGelok.COM OR SAN DIEGO FLUID SYSTEM TECHNOLOGIES 6350 NANCY RIDGE DRIVE, SUITE 101 SAN DIEGO, CA 92121 (658) 320-4000 SWAGelok P/N SS-200-6

SWAGelok FITTING, 1/8" OD TUBE IS WELDED TO UTILITY CONNECTION MODULE.

MINIMUM 36" LONG TEFLON PFA LINE REQUIRED (36" INCLUDED WITH SOURCE) FOR SAFE OPERATION. DO NOT USE METAL GAS LINES TO MEET THIS REQUIREMENT - ELECTRICAL ISOLATION IS NECESSARY.

WARNING:
TUBING, TEFLON, PFA IS AVAILABLE FROM: MC MASTER CARR 9630 NORWALK BLVD SANTA FE SPRINGS, CA 90670-2932 VOICE: (310) 692-5911 FAX: (310) 695-2323 MCMaster-CARR P/N 5180K51

WARNING:
WATER LINE TUBE UNION, IS AVAILABLE FROM: ALPHA TECHNOLOGIES 320 PREMIER COURT, SUITE 222 FRANKLIN, TN 37067 TEL: (615) 771-6650 ALPHA PART NUMBER 88040-06

SEE MATERIALS SCIENCE, INC. DOCUMENT NO. 251092 FOR PROPER INSTALLATION, OPERATION AND USE OF SUNSOURCE SPUTTERING SOURCES.

WARNING:
MATERIALS SCIENCE P/N 00000680 SPANNER WRENCH REQUIRED TO TIGHTEN NUT. FEDERAL SPEC 000-W-6656. ADJUSTABLE UP TO 2" OVERALL LENGTH: 6 3/8" PIN DIAMETER: 3/16" PIN HEIGHT: 1/8"

WARNING:
MULTI-CONTACT-USA: 5560 SKYLANE BLVD. SANTA ROSA, CA 95403 VOICE: (707) 575-7575 FAX: (707) 575-7373 INTERNET: HTTP://WWW.MULTI-CONTACT-USA.COM P/N 05.0201 LOCKING PLUG IS SUPPLIED WITH SOURCE.

WARNING:
OPTIONAL INSULATING SAFETY GUARD CAN BE PROVIDED IF USER DOES NOT SUPPLY RECOMMENDED INTERLOCKED SAFETY ENCLOSURE.

WARNING:
ADD .100 [2.54] WHEN CLAMPED TARGETS ARE USED. A TALLER SIDE ANODE SHIELD IS REQUIRED TO MAINTAIN THE PROPER DARK SPACE GAP WHEN 0.50" THICK TARGETS ARE CLAMPED TO THE "SEMI-PERMANENT MEMBRANE". BONDED AND DIRECTLY WATER COOLED TARGETS USE THE STANDARD SHIELD SHOWN IN THE OTHER VIEWS.

15. MASS OF SOURCE FULLY ASSEMBLED IS 25 LBS., DRY.

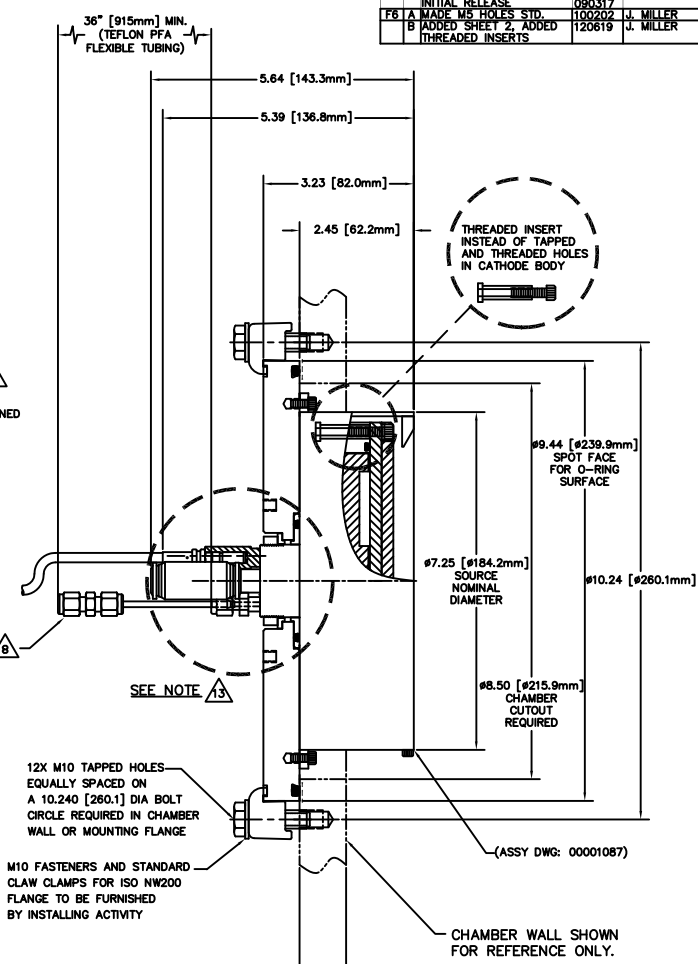
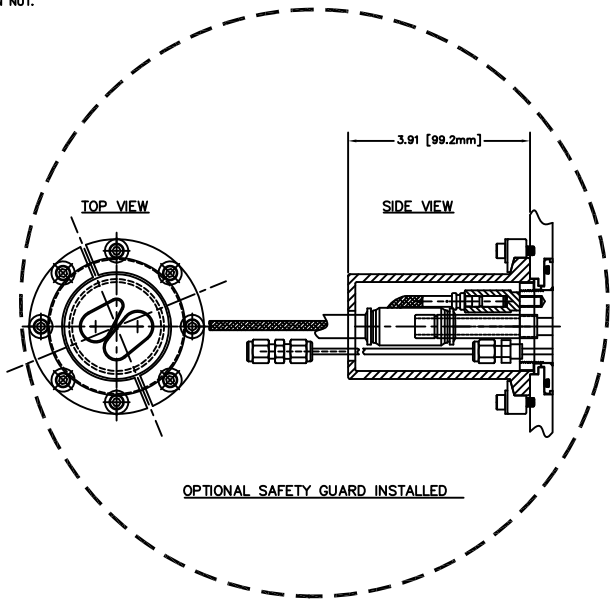
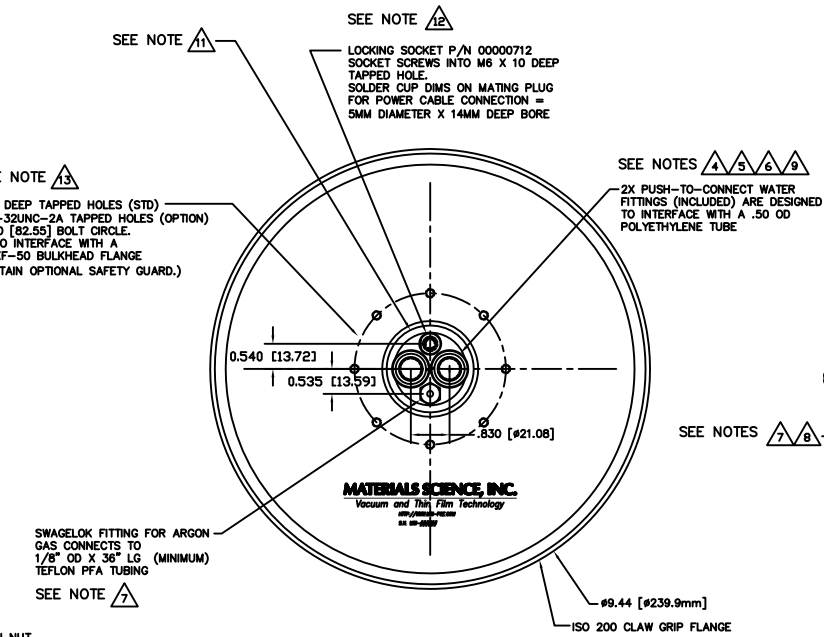

INSTALLATION CONTROL DRAWING

QUANTITY FOR ASSEMBLY	CAGE CODE	PART OR IDENTIFYING NO.	NOMENCLATURE OR DESCRIPTION	MATERIAL SPECIFICATION	ZONE	ITEM NO
			PARTS LIST			
			DATE: J. MILLER 09/08/11			
			MATERIALS SCIENCE, INC. Vacuum and Thin Film Technology			
			SUNSOURCE, 6 INCH FLANGE MOUNT, INSTALLATION CONTROL			
		789				
			DATE: E			
			00000847			
			1/1			

00000847

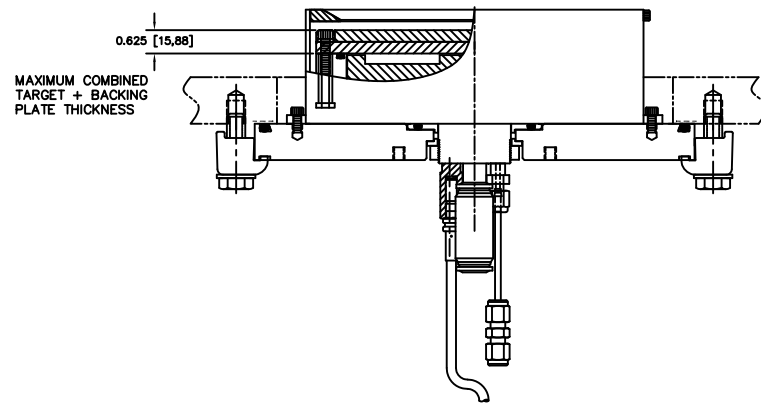

0.625 [15.88]
 MAXIMUM COMBINED
 TARGET + BACKING
 PLATE THICKNESS

BONDED TARGET ASSEMBLY
 (-1 ASSY)

TARGET MOUNTING VARIATIONS

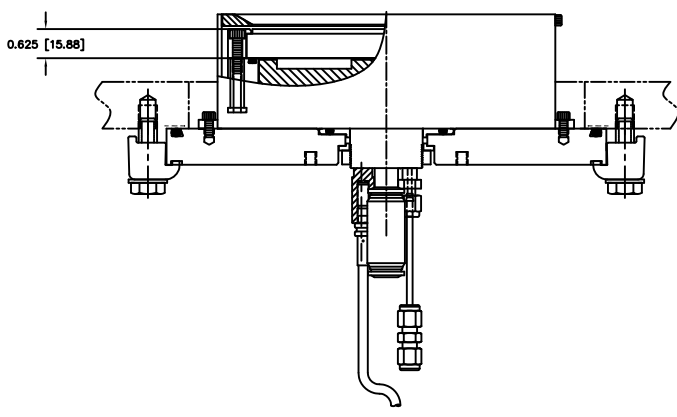

0.625 [15.88]

DIRECTLY WATER COOLED TARGET
 (-2 ASSY)

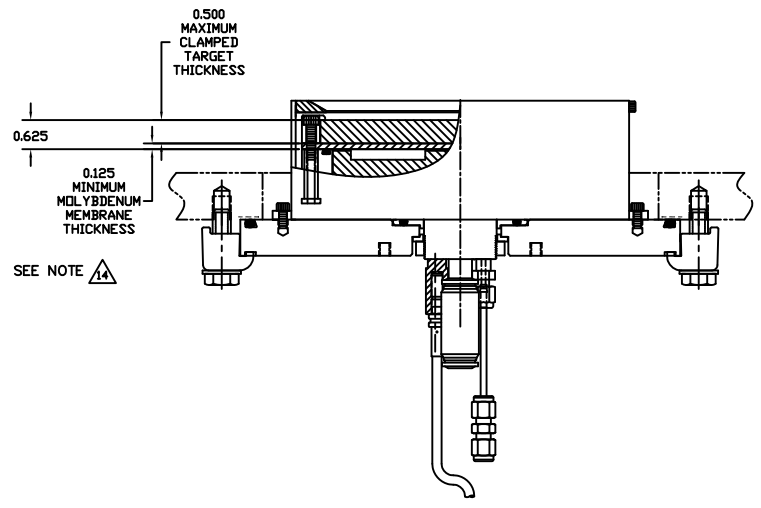

0.500
 MAXIMUM
 CLAMPED
 TARGET
 THICKNESS

0.625
 MINIMUM
 MOLYBDENUM
 MEMBRANE
 THICKNESS

SEE NOTE Δ

SEMI-PERMANENT MEMBRANE FOR
CLAMPED TARGETS (-3 ASSY)