

REV	DATE	BY	APP'D
INITIAL RELEASE	080816	J. MILLER	

- NOTES: UNLESS OTHERWISE SPECIFIED
- INTERPRET DRAWING IAW THE GLOBAL PROFESSIONAL PUBLICATIONS "DRAWING REQUIREMENTS MANUAL", EIGHTH EDITION.
  - INTERPRET DIMENSIONS AND TOLERANCES IAW ANSI Y14.5M - 1982.
  - INTERPRET ABBREVIATIONS IAW MIL-STD-12.

- WARNING:**  
WATER FITTINGS HAVE A CLEAR ID OF .25 INCHES. USING A SLEEVE OR SIMILAR DEVICE INSIDE THE WATER HOSE MAY CAUSE FLUID RESTRICTIONS AND INTERFERENCE WITH THE NORMAL OPERATION OF THE CATHODE AND THEREFORE IS NOT RECOMMENDED.
- WARNING:**  
MINIMUM HOSE LENGTH OF 60" IS REQUIRED TO ENSURE RESISTIVITY RELATIVE TO ELECTRICAL GROUND WITHIN 50 KILO OHMS. TEST CABLE WITH AN OHM METER OR OTHER SUITABLE DEVICE BEFORE USE. DO NOT USE METAL TUBING! POLYETHYLENE RECOMMENDED.

- WARNING:**  
SWAGELOCK UNION FITTING, 1/8" OD TUBE IS SUPPLIED WITH SOURCE AND ALSO AVAILABLE FROM SWAGelok COMPANY HTTP://WWW.SWAGELOK.COM OR SAN DIEGO FLUID SYSTEM TECHNOLOGIES 6350 NANCY RIDGE DRIVE, SUITE 101 SAN DIEGO, CA 92121 (858) 520-4000 SWAGELOK P/N SS-200-6 SWAGELOCK FITTING, 1/8" OD TUBE IS WELDED TO UTILITY CONNECTION MODULE.

- TUBING, TEFLON, PFA IS AVAILABLE FROM:**  
MC MASTER CARR 9630 NORWALK BLVD SANTA FE SPRINGS, CA 90670-2932 VOICE: (310) 692-5911 FAX: (310) 695-2323 MCMASTER-CARR P/N 5180K51

- WATER LINE TUBE UNION, IS AVAILABLE FROM:**  
ALPHA TECHNOLOGIES 320 PREMIER COURT, SUITE 222 FRANKLIN, TN 37067 TEL: (615) 771-8650 ALPHA PART NUMBER 88040-06

- SEE MATERIALS SCIENCE, INC. DOCUMENT NO. 251092 FOR PROPER INSTALLATION, OPERATION AND USE OF SUNSOURCE SPUTTERING SOURCES.

- MATERIALS SCIENCE P/N 00000680 SPANNER WRENCH REQUIRED TO TIGHTEN NUT. ADJUSTABLE UP TO 2" OVERALL LENGTH: 6 3/8" PIN DIAMETER: 3/16" PIN HEIGHT: 1/8"

- MULTI-CONTACT-USA: 5550 SKYLANE BLVD. SANTA ROSA, CA 95403 VOICE: (707) 575-7575 FAX: (707) 575-7373 INTERNET: HTTP://WWW.MULTI-CONTACT-USA.COM P/N 05.0201 LOCKING PLUG IS SUPPLIED WITH SOURCE.

- 3/8" O.D. WATER TUBES AND PUSH-TO-CONNECT UNIONS CAN BE REPLACED WITH 1/2" O.D. WATER LINES FOR HIGH POWER APPLICATIONS. CONTACT FACTORY.

- OPTIONAL INSULATING SAFETY GUARD CAN BE PROVIDED IF USER DOES NOT SUPPLY RECOMMENDED INTERLOCKED SAFETY ENCLOSURE.

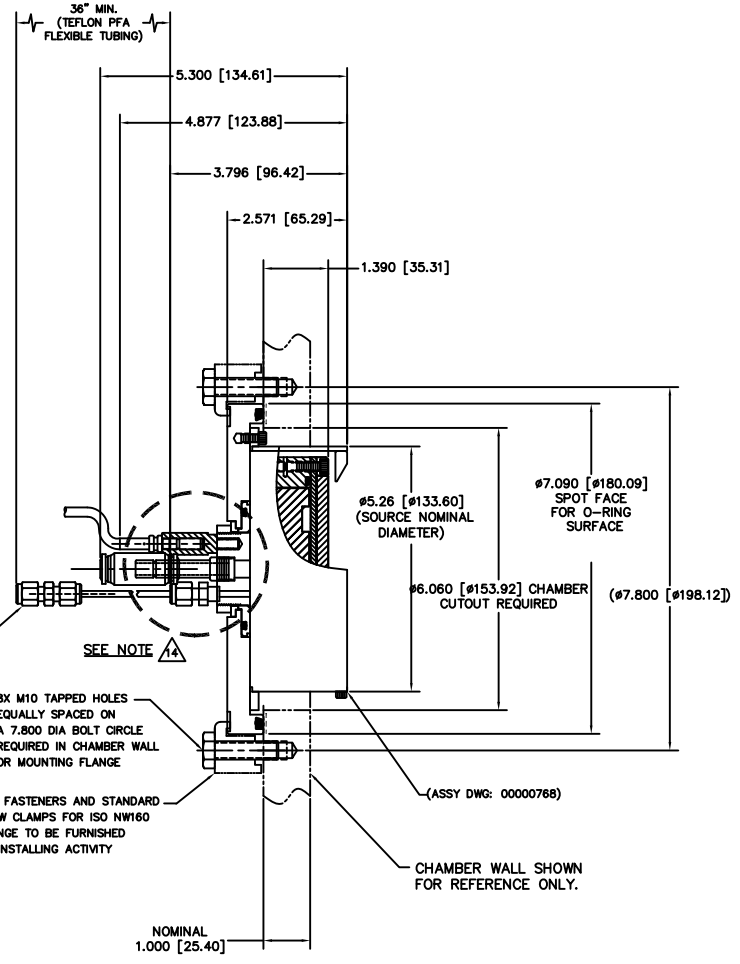
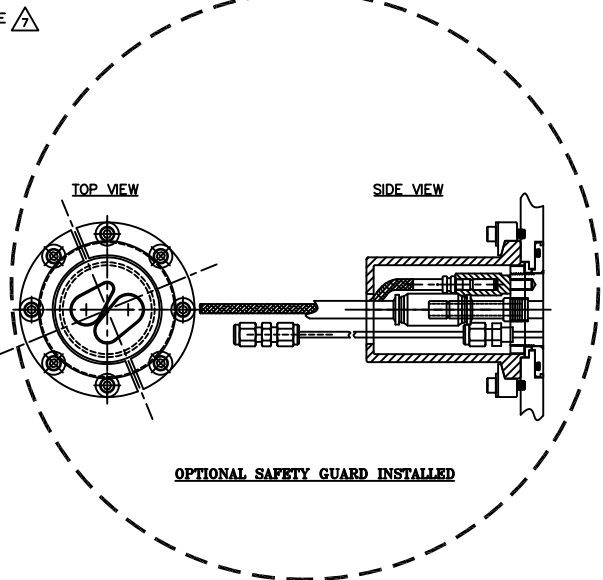
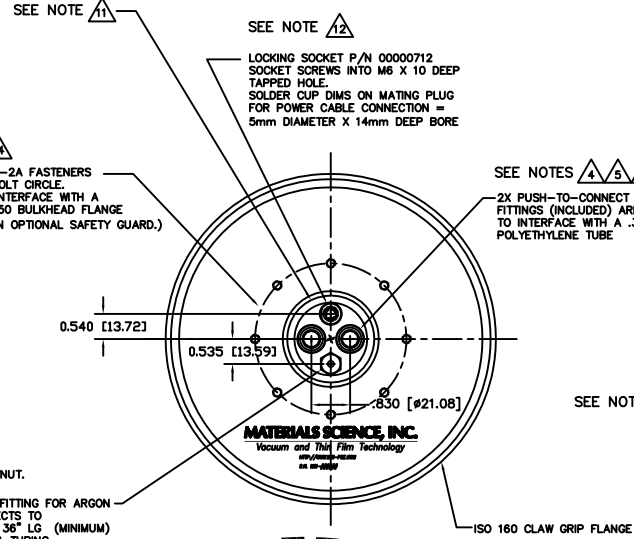

INSTALLATION CONTROL DRAWING

QUANTITY PER ASSEMBLY	CAGE CODE	PART OR IDENTIFYING NO.	NOMENCLATURE OR DESCRIPTION	MATERIAL SPECIFICATION	ZONE	ITEM NO
		726	SUNSOURCE, 4 INCH FLANGE MOUNT, INSTALLATION CONTROL			00001021
			DO NOT SCALE DRAWING			
			APPLICATION			

00001021