

REV	DATE	DESCRIPTION
1		SALES PROPOSAL RELEASE 100507

- NOTES: UNLESS OTHERWISE SPECIFIED
- INTERPRET DRAWING IAW THE GLOBAL PROFESSIONAL PUBLICATIONS "DRAWING REQUIREMENTS MANUAL", EIGHTH EDITION.
 - INTERPRET DIMENSIONS AND TOLERANCES IAW ANSI Y14.5M - 1982.
 - INTERPRET ABBREVIATIONS IAW MIL-STD-12.

⚠ WARNING:
WATER FITTINGS HAVE A CLEAR ID OF .25 INCHES. USING A SLEEVE OR SIMILAR DEVICE INSIDE THE WATER HOSE MAY CAUSE FLUID RESTRICTIONS AND INTERFERENCE WITH THE NORMAL OPERATION OF THE CATHODE AND THEREFORE IS NOT RECOMMENDED.

⚠ 5: ORIENTATION OF WATER INLET OR OUTLET IS NOT CRITICAL.

⚠ 6: **WARNING:**
MINIMUM HOSE LENGTH OF 60" IS REQUIRED TO ENSURE RESISTIVITY RELATIVE TO ELECTRICAL GROUND OF 50 KOHMS OR GREATER. TEST WITH AN OHM METER OR OTHER SUITABLE DEVICE BEFORE USE WITH WATER FLOWING. DO NOT USE METAL TUBING! POLYETHYLENE TUBING IS RECOMMENDED.

⚠ 7: MULTI-CONTACT-USA:
5560 SKYLANE BLVD.
SANTA ROSA, CA 95403
VOICE: (707) 575-7575
FAX: (707) 575-7373
INTERNET: WWW.MULTI-CONTACT-USA.COM
P/N 05.0201 LOCKING PLUG IS SUPPLIED WITH SOURCE.

8. FOR PROPER INSTALLATION, OPERATION, AND USE OF THE SUNSOURCE PLANAR MAGNETRON CATHODE(S) SEE MATERIALS SCIENCE, INC. DOCUMENT NUMBER 251091.

⚠ 9: P/N 88040-06 IS AVAILABLE FROM:
ALPHA TECHNOLOGIES
320 PREMIER COURT, SUITE 222
FRANKLIN, TN 37067
TEL: (615) 771-6650
HTTP://WWW.ALPHAFITTINGS.COM

⚠ 10: MOUNTING FLANGE AND FLANGE SPACER ARE AT GROUND POTENTIAL.

⚠ 11: SOURCE DESIGN REQUIRES THE USE OF BONDED TARGET ASSEMBLIES TO MAXIMUM TARGET UTILIZATION. THE USE OF DIRECTLY WATER COOLED TARGETS IS NOT POSSIBLE.

⚠ 12: THIS DIMENSION MAINTAINS EXISTING TARGET FACE TO CHAMBER WALL DISTANCE IN SLOAN SYSTEM.

⚠ 13: GROUND SHIELD IS SLOTTED AT BASE TO ALLOW LARGER DARK SPACE GAP THAN 0.125" DEFAULT. SPACER BETWEEN TARGET CLAMP AND INSIDE OF TOP GROUND SHIELD REQUIRED TO ESTABLISH LARGER DARK SPACE.

⚠ 14: SWAGELOCK UNION FITTING, 1/8" OD TUBE IS SUPPLIED WITH SOURCE AND ALSO AVAILABLE FROM SWAGELOK COMPANY HTTP://WWW.SWAGELOK.COM

OR
SAN DIEGO FLUID SYSTEM TECHNOLOGIES
6350 NANCY RIDGE DRIVE, SUITE 101
SAN DIEGO, CA 92121
(858) 320-4000
SWAGELOK P/N SS-200-6

SWAGELOCK FITTING, 1/8" OD TUBE IS WELDED TO UTILITY CONNECTION MODULE.

⚠ 15: TUBING, TEFLON, PFA IS AVAILABLE FROM:
MC MASTER CARR
9630 NORWALK BLVD
SANTA FE SPRINGS, CA 90670-2932
VOICE: (310) 692-5911
FAX: (310) 695-2323
MCMaster-CARR P/N 5180K51

⚠ 16: 3/8" O.D. WATER TUBES AND PUSH-TO-CONNECT UNIONS CAN BE REPLACED WITH 1/2" O.D. WATER LINES FOR HIGH POWER APPLICATIONS. CONTACT FACTORY.

⚠ 17: MATERIALS SCIENCE P/N 00000680 SPANNER WRENCH REQUIRED TO TIGHTEN NUT. FEDERAL SPEC QQQ-W-6656. ADJUSTABLE UP TO 2". OVERALL LENGTH: 6 3/8". PIN DIAMETER: 3/16". PIN HEIGHT: 1/8".

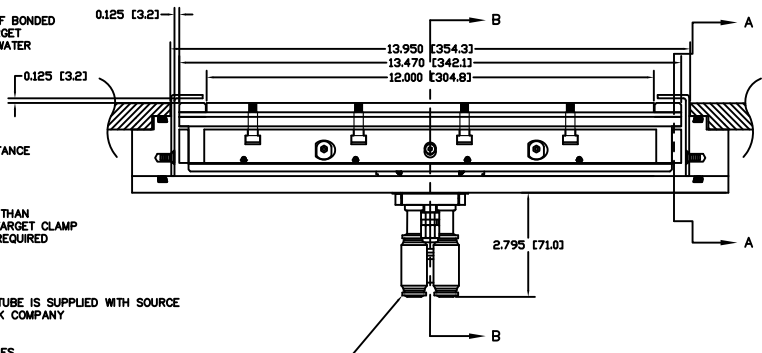
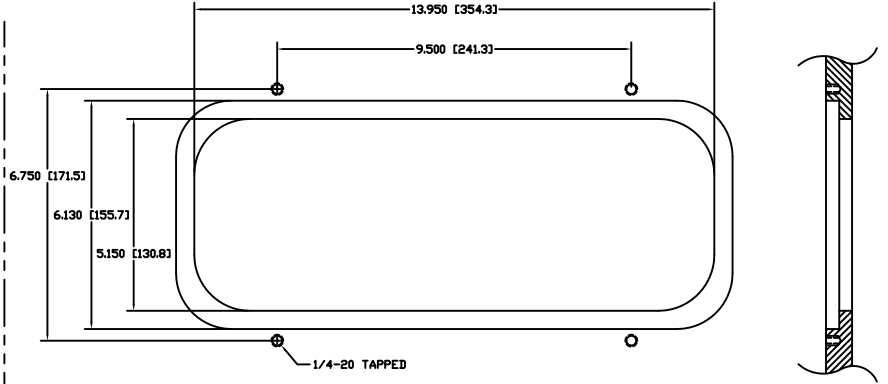
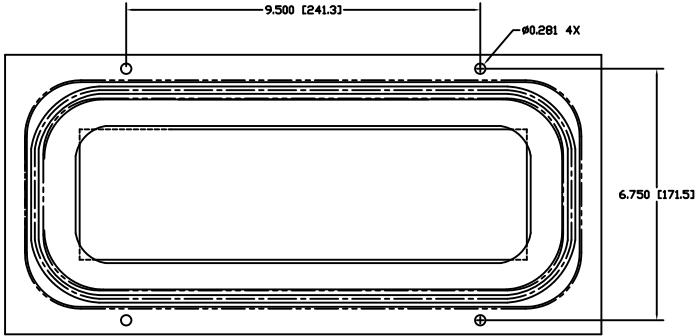

PUSH-TO-CONNECT WATER FITTINGS (INCLUDED) ARE DESIGNED TO INTERFACE WITH A .375 OD POLYETHYLENE TUBE
⚠ 5 ⚠ 6 ⚠ 16
RIGHT ANGLE FITTINGS CAN ALSO BE PROVIDED.

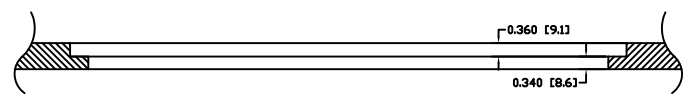

SLOAN CHAMBER CUTOUT DETAILS
CUSTOMER MUST VERIFY!!

PRELIMINARY INTERFACE
CONTROL DRAWING

QUANTITY FOR ASSEMBLY	CAGE CODE	PART OR IDENTIFYING NO.	NOMENCLATURE OR DESCRIPTION	MATERIAL SPECIFICATION	ZONE	ITEM NO
			PARTS LIST			
			DATE: J. MILLER 10/04/07	MATERIALS SCIENCE, INC. Vacuum and Thin Film Technology Department		
			RETROFIT 3.5" X 12" SLOAN ORBITORR			
			REV: E	DATE: 10/04/07	ISSUE NO: 00002106	REV: 1
			APPLICATION	DO NOT SCALE DRAWING		2

00002106

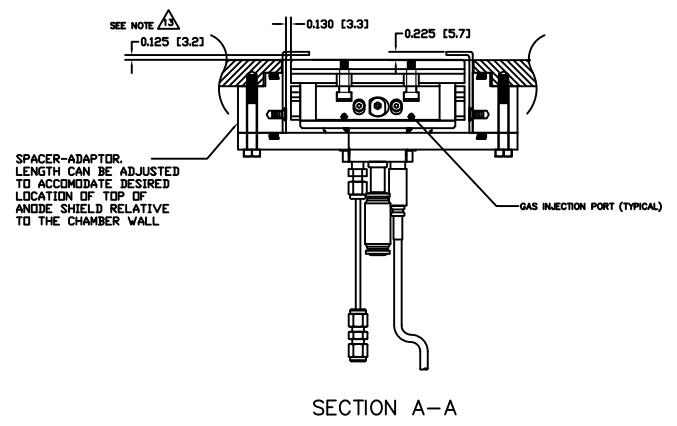
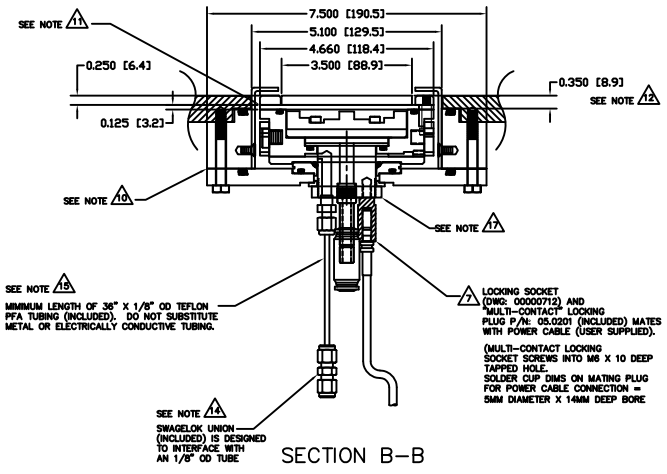

00002106