

BONDED TARGET ASSEMBLY SHOWN

SECTION A-A

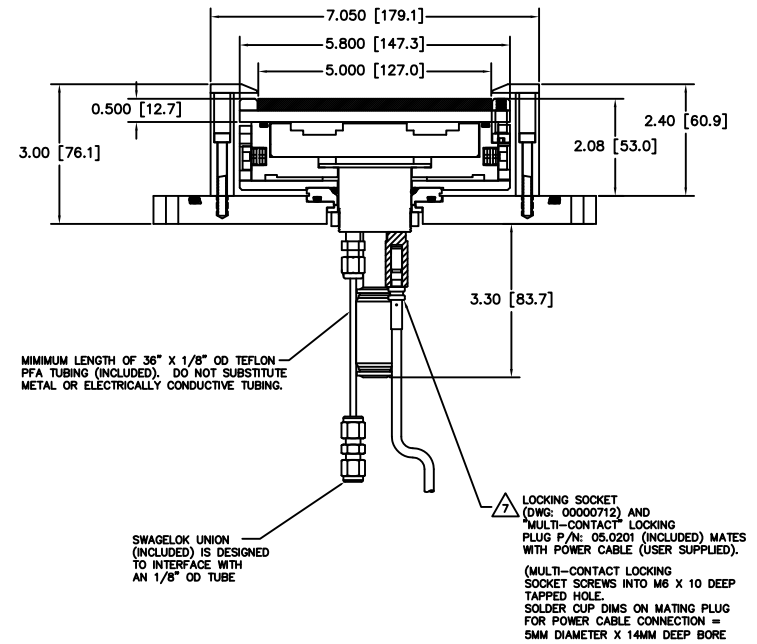

BONDED TARGET ASSEMBLY SHOWN

SECTION B-B

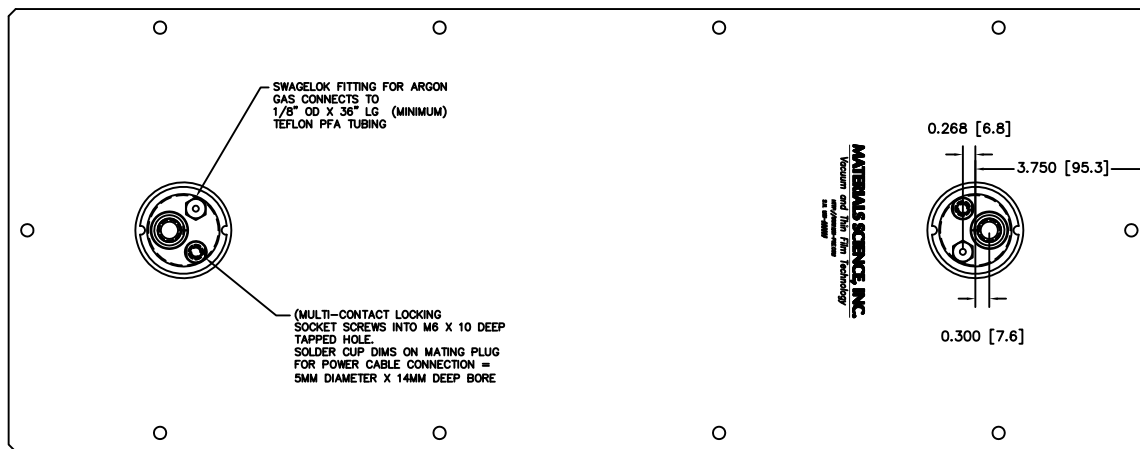

ATMOSPHERE SIDE

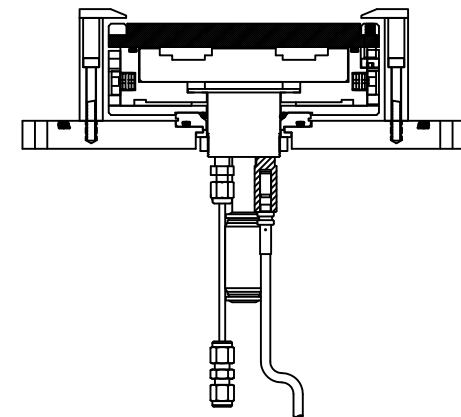

DIRECT WATER COOLED TARGET SHOWN