

REV	DATE	DESCRIPTION	BY	APP'D
1		INITIAL RELEASE	100710	
2		MINOR DIMENSION UPDATE	110914	J. MILLER

- NOTES: UNLESS OTHERWISE SPECIFIED
- INTERPRET DRAWING IAW THE GLOBAL PROFESSIONAL PUBLICATIONS "DRAWING REQUIREMENTS MANUAL", EIGHTH EDITION.
  - INTERPRET DIMENSIONS AND TOLERANCES IAW ANSI Y14.5M - 1982.
  - INTERPRET ABBREVIATIONS IAW MIL-STD-12.
  - WARNING:**  
WATER FITTINGS HAVE A CLEAR ID OF .375". USING A SLEEVE OR SIMILAR DEVICE INSIDE THE WATER HOSE MAY CAUSE FLUID RESTRICTIONS AND INTERFERENCE WITH THE NORMAL OPERATION OF THE CATHODE AND THEREFORE IS NOT RECOMMENDED.
  - WATER CHANNELS ARE SYMMETRICAL THROUGHOUT. ORIENTATION OF WATER INLET OR OUTLET IS NOT CRITICAL.
  - WARNING:**  
MINIMUM HOSE LENGTH OF 60" [1524 MM] IS REQUIRED TO ENSURE RESISTIVITY RELATIVE TO ELECTRICAL GROUND WITHIN 50 KILO OHMS. TEST CABLE WITH AN OHM METER OR OTHER SUITABLE DEVICE BEFORE USE.
  - MULTI-CONTACT-USA:  
5560 SKYLANE BLVD.  
SANTA ROSA, CA 95403  
VOICE: (707) 575-7575  
FAX: (707) 575-7373  
INTERNET:  
www.multi-contact-usa.com
  - FOR PROPER INSTALLATION, OPERATION, AND USE OF THE SUNSOURCE PLANAR MAGNETRON CATHODE(S), SEE MATERIALS SCIENCE, INC. DOCUMENT NUMBER 251091.
  - P/N 88040-08 IS AVAILABLE FROM:  
ALPHA TECHNOLOGIES  
320 PREMIER COURT, SUITE 222  
FRANKLIN, TN 37067  
TEL: (615) 771-6650  
HTTP://WWW.ALPHAFITTINGS.COM
  - ALL FASTENERS ARE METRIC.
  - DIMENSIONS IN BRACKETS "[ ]" DENOTE REFERENCE DIMENSIONS IN MILLIMETERS.
  - TARGET UTILIZATION IS HIGHEST FOR BONDED & CLAMPED TARGETS. DIRECTLY WATER COOLED TARGETS MUST BE SLIGHTLY LONGER & WIDER - THIS EXTRA AREA IS NOT SPUTTERED. THEREFORE TARGET UTILIZATION IS LOWER - BY DEFINITION.
  - ADD .100 [2.54] WHEN CLAMPED TARGETS ARE USED. A TALLER SET OF SIDE ANODE/GROUND SHIELDS ARE REQUIRED TO MAINTAIN THE PROPER DARK SPACE GAP WHEN CLAMPED TARGETS ARE USED. BONDED AND DIRECTLY WATER COOLED TARGETS USE THE STANDARD SIDE SHIELDS SHOWN AND DIMENSIONED.

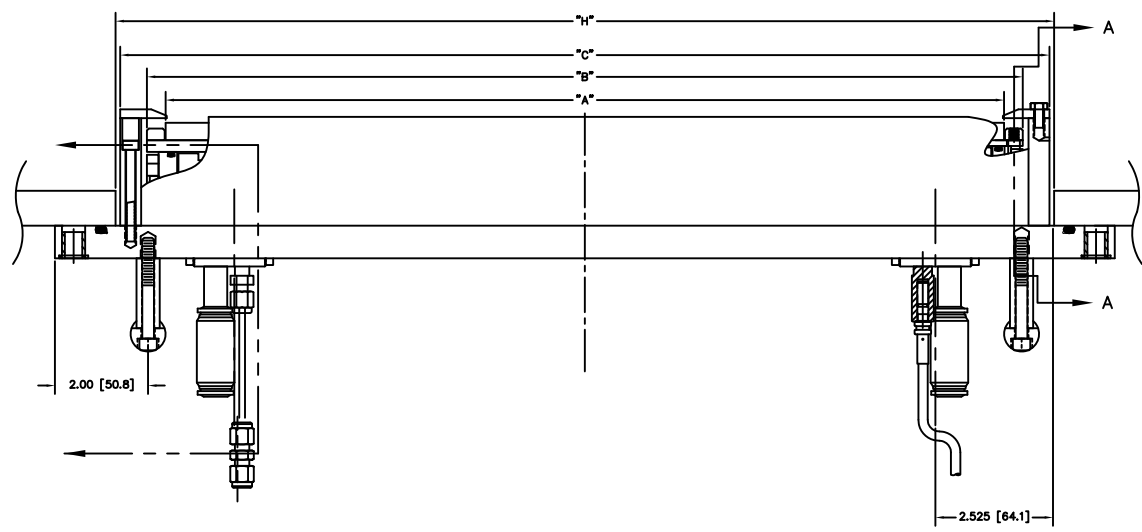
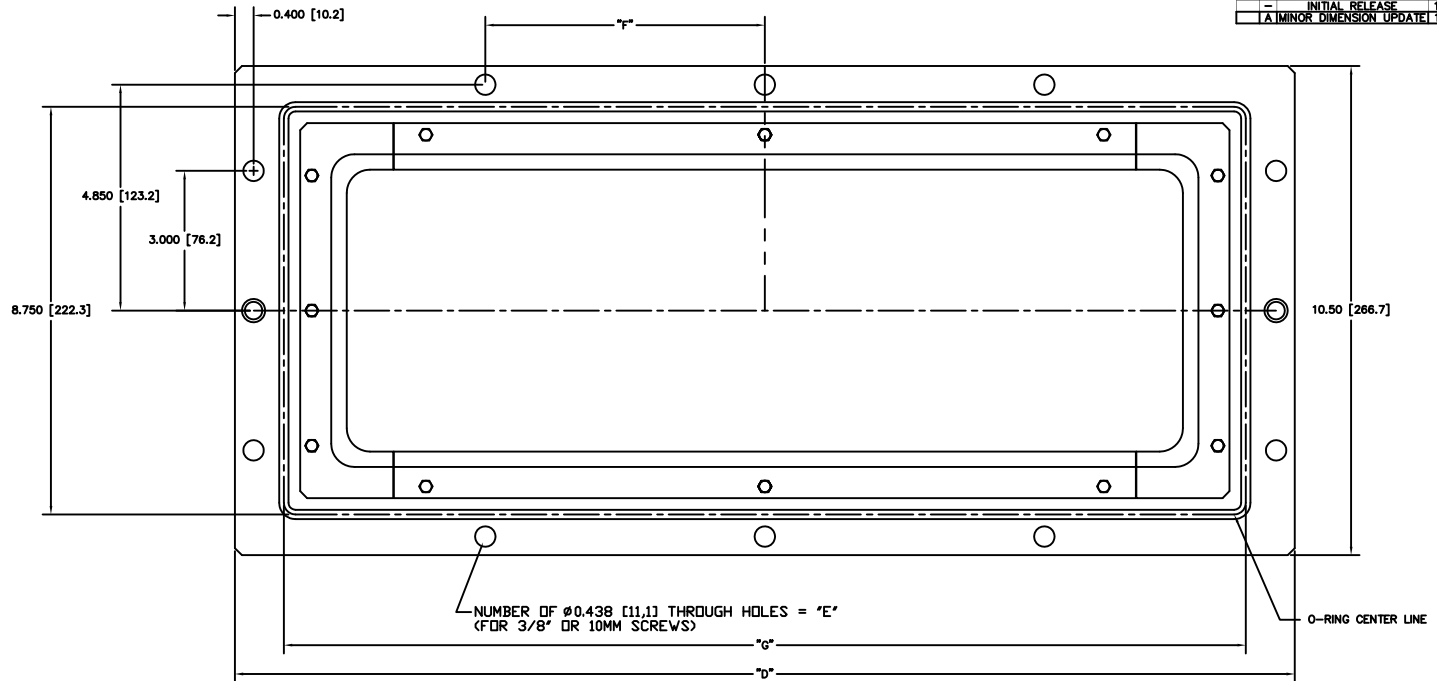

TARGET LENGTH	"A" DIMENSION	"B" DIMENSION	"C" DIMENSION	"D" DIMENSION
8 [203,2]	8.000 [203,2]	8.80 [223,5]	9.95 [252,7]	12.75 [323,9]
10 [254,0]	10.000 [254,0]	10.80 [274,3]	11.95 [303,5]	14.75 [374,7]
12 [304,8]	12.000 [304,8]	12.80 [325,1]	13.95 [354,3]	16.75 [425,5]
15 [381,0]	15.000 [381,0]	15.80 [401,3]	16.95 [430,5]	19.75 [501,7]
20 [508,0]	20.000 [508,0]	20.80 [528,3]	21.95 [557,5]	24.75 [628,7]

TARGET LENGTH	"E" DIMENSION	"F" DIMENSION	"G" DIMENSION	"H" DIMENSION
8 [203,2]	6 EACH	3.500 [88,9]	10.65 [270,5]	"C" + .20 [5,1]
10 [254,0]	6 EACH	3.500 [88,9]	12.65 [321,3]	"C" + .20 [5,1]
12 [304,8]	8 EACH	6.000 [152,4]	14.65 [372,1]	"C" + .20 [5,1]
15 [381,0]	8 EACH	6.000 [152,4]	17.65 [448,3]	"C" + .20 [5,1]
20 [508,0]	10 EACH	6.000 [152,4]	22.65 [575,3]	"C" + .20 [5,1]

- NOTES:
- TARGET DIMENSIONS NOTED IN TABLE ARE FOR COMMON SIZES.
  - OTHER TARGET LENGTHS CAN BE ACCOMMODATED.
  - LINEAR DIMENSIONS IN TABLE SCALE EXACTLY.
  - "G" DIMENSION = 2.75 PLUS TARGET LENGTH

# INSTALLATION CONTROL DRAWING

QUANTITY FOR ASSEMBLY	CAGE CODE	PART OR IDENTIFYING NO.	NOMENCLATURE OR DESCRIPTION	MATERIAL SPECIFICATION	ZONE	ITEM NO
			PARTS LIST			
			DATE: J. MILLER 10/01/10			
			MATERIALS SCIENCE, INC. Vacuum and Thin Film Technology			
			SUNSOURCE, 6" WIDE FLANGE MOUNT, SHORT, LOW POWER			
			DATE: 1/1			
			USED ON			00002121
			APPLICATION			2

00002121

8 7 6 5 4 3 2 1

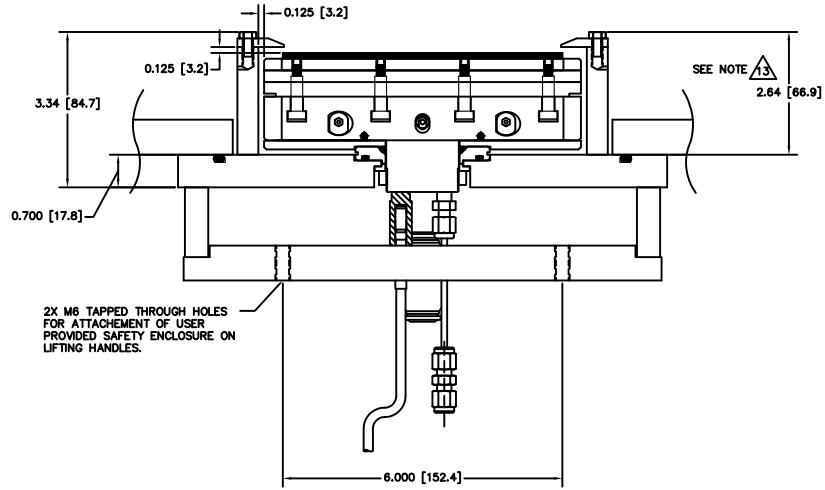

**BONDED TARGET ASSEMBLY SHOWN**

SECTION A-A

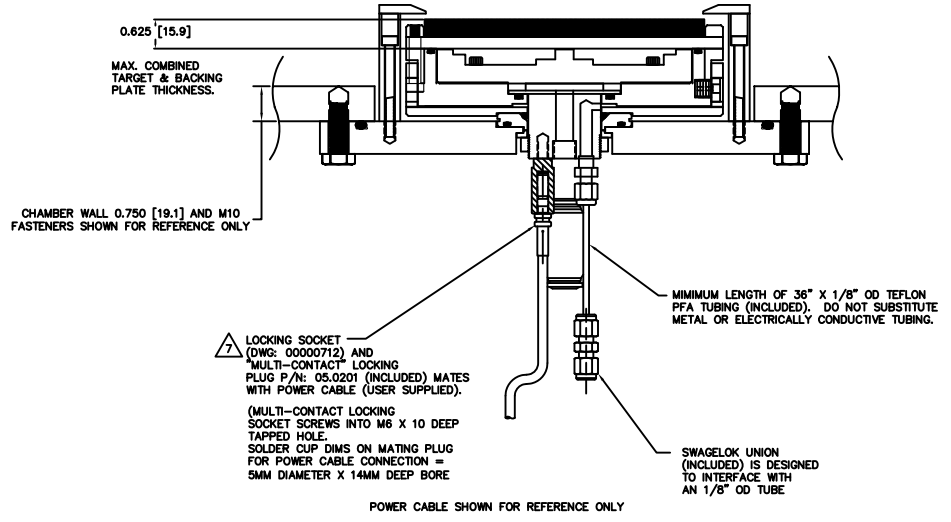

**BONDED TARGET ASSEMBLY SHOWN**

SECTION B-B

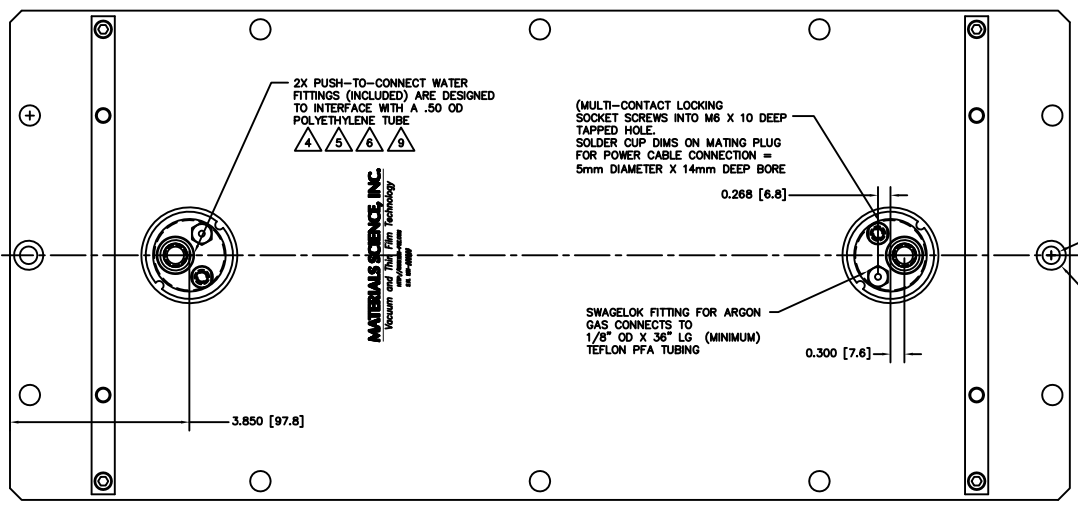

ATMOSPHERE SIDE

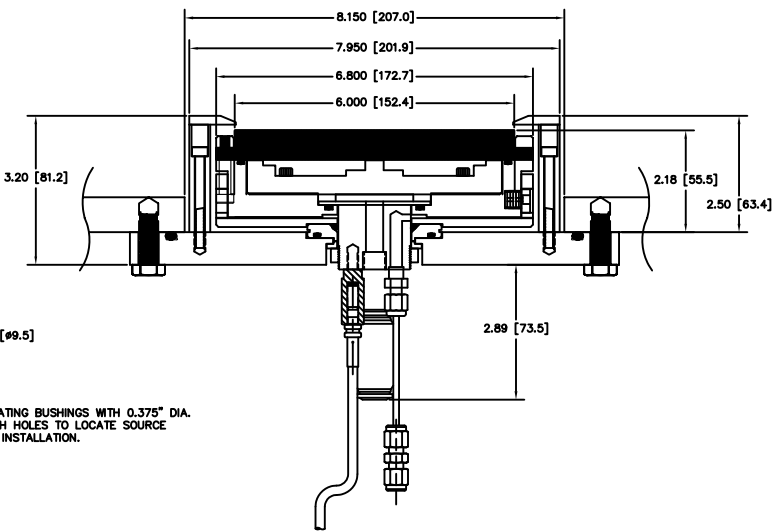

**DIRECT WATER COOLED TARGET SHOWN**

8 7 6 5 4 3 2 1