

REV	DATE	DESCRIPTION	BY	APP'D
1	INITIAL RELEASE	100827		
A.1	ADDED TARGET VIEWS	110508	J. MILLER	

- NOTES: UNLESS OTHERWISE SPECIFIED
- INTERPRET DRAWING IAW THE GLOBAL PROFESSIONAL PUBLICATIONS "DRAWING REQUIREMENTS MANUAL", EIGHTH EDITION.
  - INTERPRET DIMENSIONS AND TOLERANCES IAW ANSI Y14.5M - 1982.
  - INTERPRET ABBREVIATIONS IAW MIL-STD-12.
  - MASS OF CATHODE FULLY ASSEMBLED IS 20 LBS., DRY.

**5** WARNING: WATER FITTINGS HAVE A CLEAR ID OF .375 INCHES. USING A SLEEVE OR SIMILAR DEVICE INSIDE THE WATER HOSE MAY CAUSE FLUID RESTRICTIONS AND INTERFERENCE WITH THE NORMAL OPERATION OF THE CATHODE AND THEREFORE IS NOT RECOMMENDED.

**6** WATER CHANNELS ARE SYMMETRICAL THROUGHOUT. ORIENTATION OF WATER INLET OR OUTLET IS NOT CRITICAL.

**7** WARNING: MINIMUM HOSE LENGTH OF 60" IS REQUIRED TO ENSURE RESISTIVITY RELATIVE TO ELECTRICAL GROUND WITHIN 50 KILO OHMS. TEST CABLE WITH AN OHM METER OR OTHER SUITABLE DEVICE BEFORE USE.

**8** MULTI-CONTACT-USA: 5560 SKYLANE BLVD. SANTA ROSA, CA 95403 VOICE: (707) 575-7575 FAX: (707) 575-7375 INTERNET: WWW.MULTICONTACT-USA.COM

**9** FOR PROPER INSTALLATION, OPERATION, AND USE OF THE SUNSOURCE PLANAR MAGNETRON CATHODE(S) SEE MATERIALS SCIENCE, INC. DOCUMENT NUMBER 251092.

**10** P/N 88040-08 IS AVAILABLE FROM: ALPHA TECHNOLOGIES 320 PREMIER COURT, SUITE 222 FRANKLIN, TN 37067 TEL: (615) 771-6650 HTTP://WWW.ALPHAFITTINGS.COM

**11** GAS FITTING (INCLUDED), SWAGelok IS AVAILABLE FROM: HTTP://WWW.SWAGELOK.COM

**12** MINIMUM 36" LONG TEFLON PFA LINE REQUIRED (36" INCLUDED WITH SOURCE) FOR SAFE OPERATION. DO NOT USE METAL GAS LINES TO MEET THIS REQUIREMENT - ELECTRICAL ISOLATION IS NECESSARY.

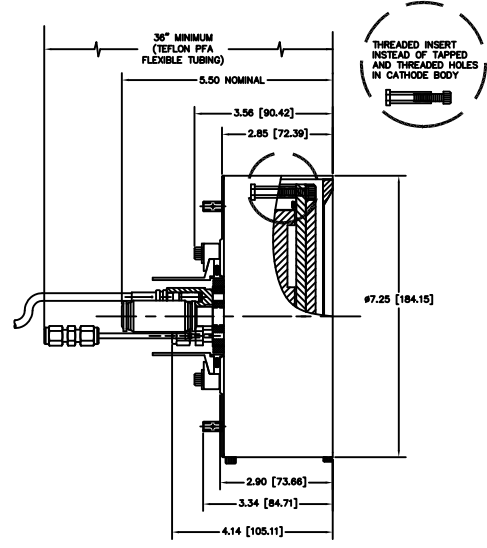
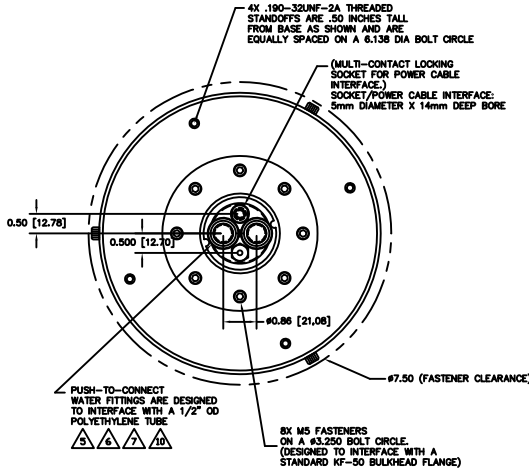

**TARGET MOUNTING VARIATIONS**

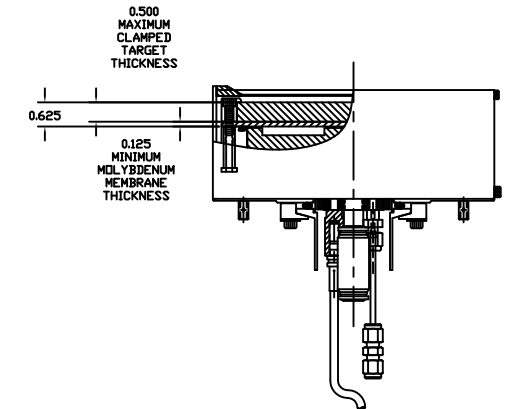
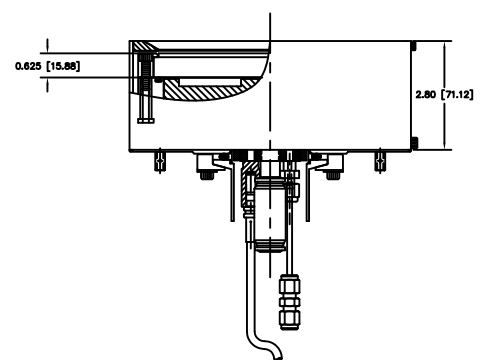
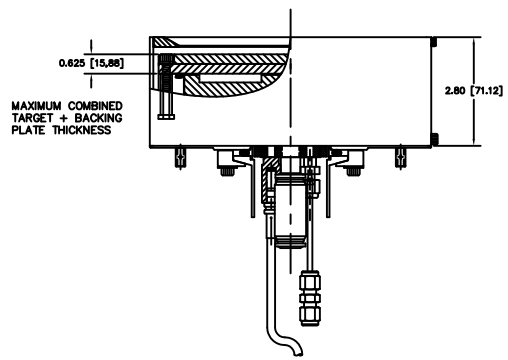

**INSTALLATION CONTROL DRAWING**

QUANTITY FOR ASSEMBLY	CAGE CODE	PART OR IDENTIFYING NO.	NOMENCLATURE OR DESCRIPTION	MATERIAL SPECIFICATION	ZONE	ITEM NO
			<b>PARTS LIST</b>			
			DATE: J. MILLER 10/04/97			
			MATERIALS SCIENCE, INC. Vacuum and Thin Film Technology			
			SUNSOURCE, 6" ROUND INTERNAL GEN II, INSERT STYLE			
			DATE: 1/1			
			USED ON			
			APPLICATION			

00002130