

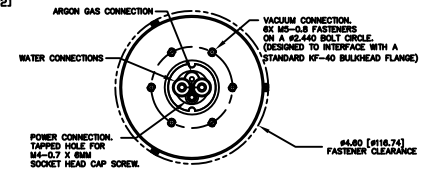

-1, -2, AND -3 ASSY SHOWN

DASH NO	DIM "A"
-1	12"
-2	18"
-3	24"

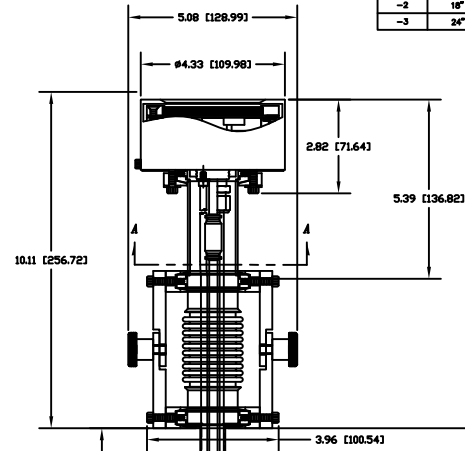
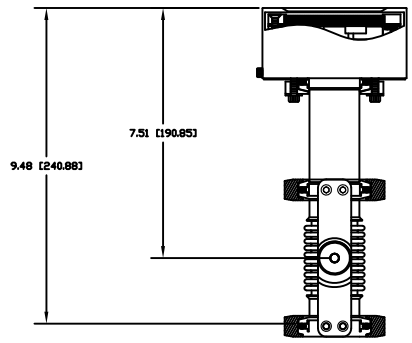

SECTION "A-A"

TOP VIEW

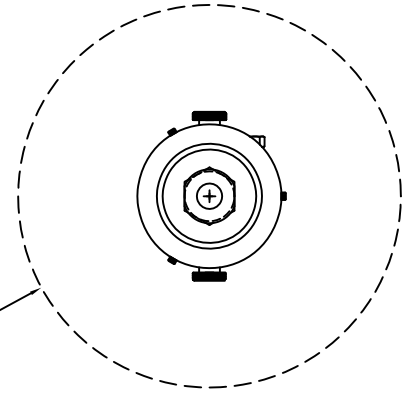

ALLOW #1.50 [38.10] CLEARANCE @ 30° TILT ANGLE

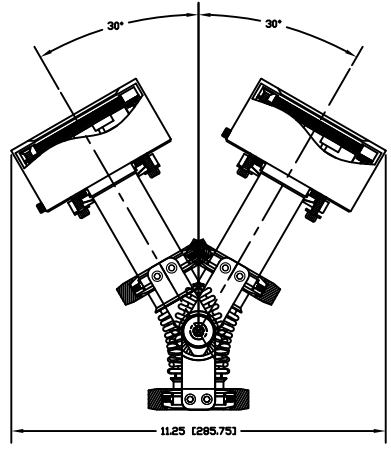

.50 - 1.125 [12.7 - 28.5] BASEPLATE/CHAMBER WALL THICKNESS

17.16 [435.881]

WATER FITTINGS ARE DESIGNED TO INTERFACE WITH A 1/4" OD POLYETHYLENE OR POLYPROPYLENE TUBE  
SEE NOTES

SEE NOTE

FEMALE IN CONNECTOR @ 300 WATTS MAXIMUM RF POWER LEVELS.

FEMALE DIN 7/16 CONNECTOR @ GREATER THAN 300 WATTS RF POWER LEVELS.

00002135