

- NOTES: UNLESS OTHERWISE SPECIFIED
- INTERPRET DRAWING IAW THE GLOBAL PROFESSIONAL PUBLICATIONS "DRAWING REQUIREMENTS MANUAL", EIGHTH EDITION.
 - INTERPRET DIMENSIONS AND TOLERANCES IAW ANSI Y14.5M - 1982.
 - INTERPRET ABBREVIATIONS IAW MIL-STD-12.
 - MASS OF CATHODE FULLY ASSEMBLED IS 40 LBS., DRY.

WARNING:
WATER FITTINGS HAVE A CLEAR ID OF .375 INCHES. USING A SLEEVE OR SIMILAR DEVICE INSIDE THE WATER HOSE MAY CAUSE FLUID RESTRICTIONS AND INTERFERENCE WITH THE NORMAL OPERATION OF THE CATHODE AND THEREFORE IS NOT RECOMMENDED.

WARNING:
WATER CHANNELS ARE SYMMETRICAL THROUGHOUT. ORIENTATION OF WATER INLET OR OUTLET IS NOT CRITICAL.

WARNING:
MINIMUM HOSE LENGTH OF 60" IS REQUIRED TO ENSURE RESISTIVITY RELATIVE TO ELECTRICAL GROUND WITHIN 50 KILO OHMS. TEST CABLE WITH AN OHM METER OR OTHER SUITABLE DEVICE BEFORE USE.

MULTI-CONTACT-USA:
5560 SKYLANE BLVD.
SANTA ROSA, CA 95403
VOICE: (707) 575-7575
FAX: (707) 575-7375
INTERNET: WWW.MULTICONTACT-USA.COM

FOR PROPER INSTALLATION, OPERATION, AND USE OF THE SUNSOURCE PLANAR MAGNETRON CATHODE(S) SEE MATERIALS SCIENCE, INC. DOCUMENT NUMBER 251092.

P/N 88040-08 IS AVAILABLE FROM:
ALPHA TECHNOLOGIES
320 PREMIER COURT, SUITE 222
FRANKLIN, TN 37067
TEL: (615) 771-6650
HTTP://WWW.ALPHAFITTINGS.COM

GAS FITTING (INCLUDED), SWAGELOK IS AVAILABLE FROM:
HTTP://WWW.SWAGELOK.COM

MINIMUM 36" LONG TEFLON PFA LINE REQUIRED (36" INCLUDED WITH SOURCE) FOR SAFE OPERATION. DO NOT USE METAL GAS LINES TO MEET THIS REQUIREMENT - ELECTRICAL ISOLATION IS NECESSARY.

4X .190-32UNF-2A THREADED STANDOFFS ARE .50 INCHES TALL FROM BASE AS SHOWN AND ARE EQUALLY SPACED ON A 8.138 DIA BOLT CIRCLE

8X M5 FASTENERS ON A Ø3.250 BOLT CIRCLE (DESIGNED TO INTERFACE WITH A STANDARD KF-50 BULKHEAD FLANGE)

SWAGELOK FITTING FOR ARGON GAS CONNECTS TO 1/8" OD X 3/8" LG (MINIMUM) TEFLON PFA TUBING

SWAGELOK UNION (INCLUDED) IS DESIGNED TO INTERFACE WITH AN 1/8" OD TUBE

PUSH-TO-CONNECT WATER FITTINGS ARE DESIGNED TO INTERFACE WITH A 1/2" OD POLYETHYLENE TUBE

POWER CABLE SHOWN FOR REFERENCE ONLY

LOCKING SOCKET (DIMS: 0000712) AND MULTI-CONTACT LOCKING PLUG (P/N: 05020) (INCLUDED) MATES WITH POWER CABLE (USER SUPPLIED). (MULTI-CONTACT LOCKING SOCKET SCREWS INTO M6 X 10 DEEP TAPPED HOLE. SOLDER CLIP DIMS ON MATING PLUG FOR POWER CABLE CONNECTION = 5MM DIAMETER X 14MM DEEP BORE

THREADED INSERT INSTEAD OF TAPPED AND THREADED HOLES IN CATHODE BODY

BULKHEAD KF-50 CLAMP SET AND CENTERING RING ASSEMBLY ARE INCLUDED. FEEDTHROUGH ASSEMBLY TO BE FURNISHED BY USER

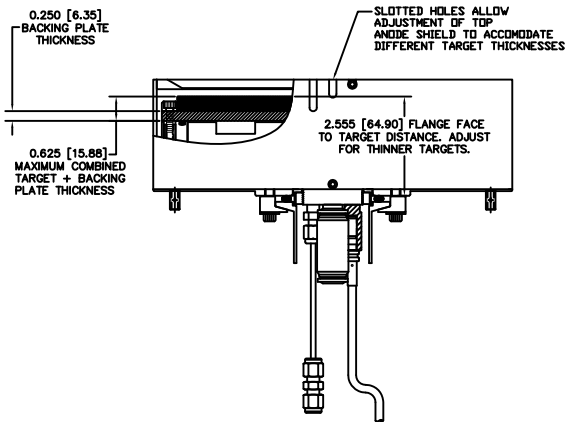

BONDED TARGET ASSEMBLY (-1 ASSY)

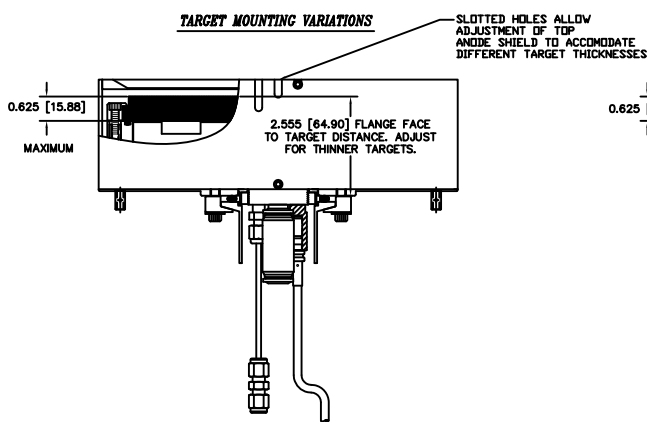

DIRECTLY WATER-COOLED TARGET (-2 ASSY)

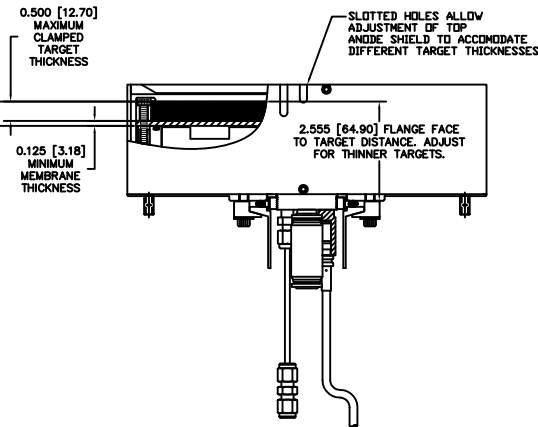

SEMI-PERMANENT MEMBRANE FOR CLAMPED TARGETS (-3 ASSY)

INSTALLATION CONTROL DRAWING

REV	DESCRIPTION	DATE	APP'D
1	INITIAL RELEASE	100826	J. MILLER
2	CHANGED - 3 VIEW	110127	J. MILLER
3	MULTIPLE SMALL DIMENSIONAL CHANGES	110724	J. MILLER
4	GS 1 C ADD THREADED STANDOFF	120422	J. MILLER

QUANTITY PER ASSEMBLY	CAGE CODE	PART OR IDENTIFYING NO.	NOMENCLATURE OR DESCRIPTION	MATERIAL SPECIFICATION	ZONE	ITEM NO
			PARTS LIST			
			DATE: J. MILLER 10/06/20			
			MATERIALS SCIENCE, INC. Vacuum and Thin Film Technology			
			SUNSOURCE, 8" ROUND INTERNAL GEN II, INSERT STYLE			
			DATE: E			00002144
			APPLICATION			1/1

00002144