

REV	DATE	DESCRIPTION	BY	APP'D
INITIAL RELEASE	100924			

- NOTES: UNLESS OTHERWISE SPECIFIED
- INTERPRET DRAWING IAW THE GLOBAL PROFESSIONAL PUBLICATIONS "DRAWING REQUIREMENTS MANUAL", EIGHTH EDITION.
  - INTERPRET DIMENSIONS AND TOLERANCES IAW ANSI Y14.5M - 1982.
  - INTERPRET ABBREVIATIONS IAW MIL-STD-12.
  - GAS FITTING (INCLUDED), SWAGelok (ITEM 9) IS AVAILABLE FROM: HTTP://WWW.SWAGelok.COM**
  - MINIMUM 60" LONG POLYETHYLENE LINES REQUIRED FOR SAFE OPERATION. USER MUST SUPPLY ADDITIONAL 42" LONG POLYETHYLENE WATER LINES TO MEET THIS REQUIREMENT. DO NOT SUBSTITUTE METAL WATER FITTINGS FOR ITEM 8.
  - WATER LINE CONNECTORS (INCLUDED, ITEM 8) ARE AVAILABLE FROM: HTTP://WWW.JOHNGUEST.COM**
  - MINIMUM 36" LONG TEFLON PFA LINE REQUIRED (36" INCLUDED WITH SOURCE) FOR SAFE OPERATION. DO NOT USE METAL GAS LINES TO MEET THIS REQUIREMENT - ELECTRICAL ISOLATION IS NECESSARY.
  - DO NOT DING, SCRATCH OR GOUGE POLISHED SURFACE.
  - SEE MATERIALS SCIENCE, INC. DOCUMENT NO. 251011 FOR PROPER INSTALLATION, OPERATION AND USE OF POLARIS SPUTTERING SOURCES.
  - MASS OF SPUTTERING SOURCE ASSEMBLY FULLY ASSEMBLED IS 6 LBS., DRY.

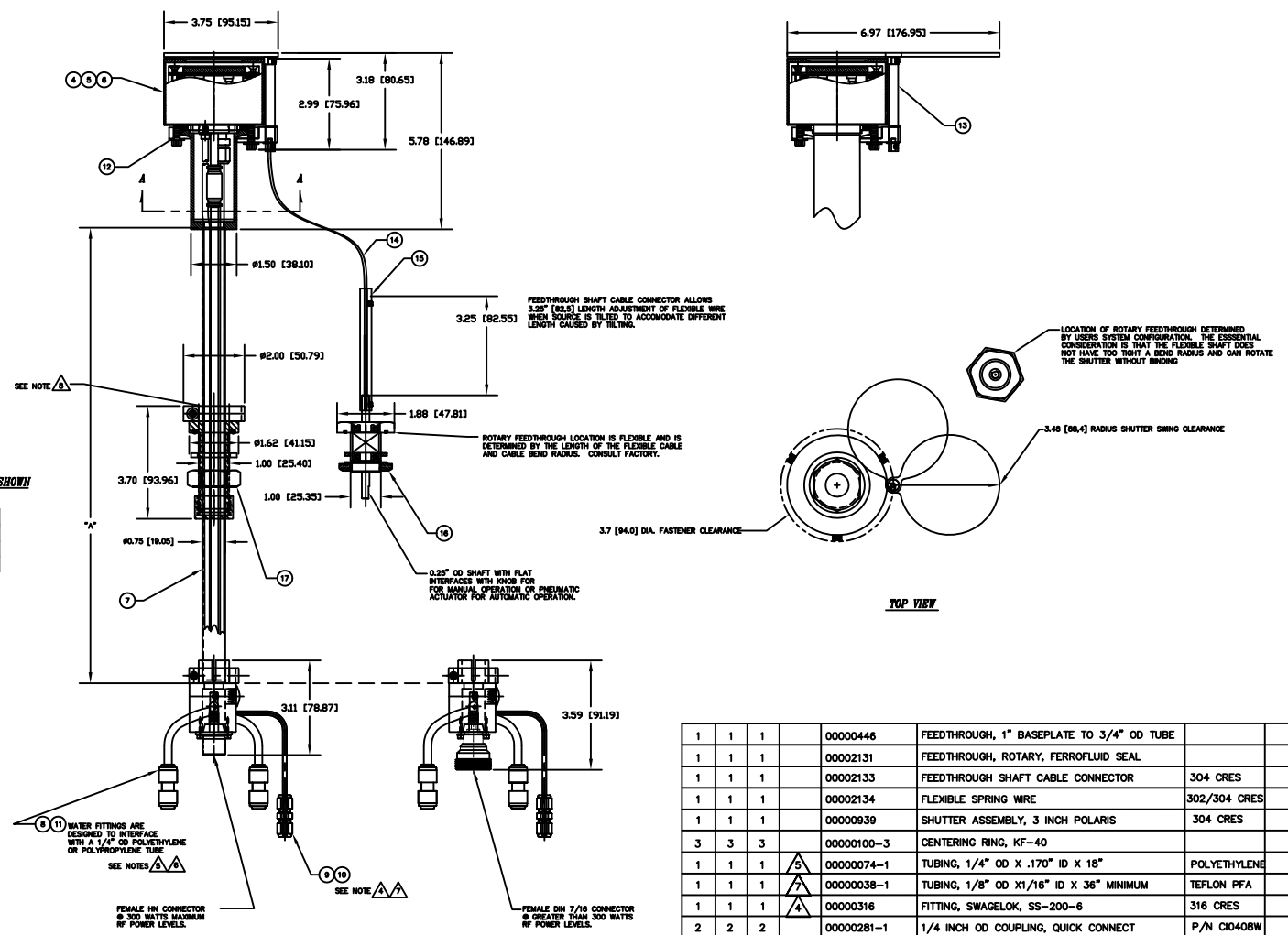

-1, -2, AND -3 ASST SHOWN

DASH NO	DIM "A"
-1	12"
-2	18"
-3	24"

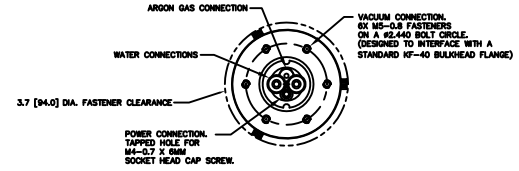

QTY	REV	DESCRIPTION	MATERIAL SPECIFICATION	ZONE	ITEM NO	
1	1	1	00000446	FEEDTHROUGH, 1" BASEPLATE TO 3/4" OD TUBE	17	
1	1	1	00002131	FEEDTHROUGH, ROTARY, FERROFLUID SEAL	16	
1	1	1	00002133	FEEDTHROUGH SHAFT CABLE CONNECTOR	304 CRES	15
1	1	1	00002134	FLEXIBLE SPRING WIRE	302/304 CRES	14
1	1	1	00000939	SHUTTER ASSEMBLY, 3 INCH POLARIS	304 CRES	13
3	3	3	00000100-3	CENTERING RING, KF-40		12
1	1	1	00000074-1	TUBING, 1/4" OD X .170" ID X 18"	POLYETHYLENE	11
1	1	1	00000038-1	TUBING, 1/8" OD X 1/16" ID X 36" MINIMUM	TEFLON PFA	10
1	1	1	00000316	FITTING, SWAGelok, SS-200-6	316 CRES	9
2	2	2	00000281-1	1/4 INCH OD COUPLING, QUICK CONNECT	P/N C1040BW	8
1	1	1	00000790	3/4 INCH TUBE FEEDTHROUGH ASSEMBLY	304 CRES	7
1			00000773-3	2 INCH INTERNAL CATHODE (CLAMPED TARGET)		6
1			00000773-2	2 INCH INT CATHODE (DIRECT WATER COOLED TGT)		5
1			00000773-1	2 INCH INTERNAL CATHODE (BONDED TARGET)		4
			00002173-3	2" POLARIS SOURCE, VARIABLE WITH SHUTTER		3
			00002173-2	2" POLARIS SOURCE, VARIABLE WITH SHUTTER		2
			00002173-1	2" POLARIS SOURCE, VARIABLE WITH SHUTTER		1

INSTALLATION CONTROL DRAWING

QUANTITY FOR ASSEMBLY	CASE CODE	PART OR IDENTIFYING NO.	NOMENCLATURE OR DESCRIPTION	MATERIAL SPECIFICATION	ZONE	ITEM NO
PARTS LIST						
DATE: 10/09/24			MATERIALS SCIENCE, INC. Vacuum and Thin Film Technology			
NEXT ASSEMBLY			2" POLARIS, VARIABLE POSITION WITH SHUTTER 1" B.P. FEEDTHRU			
APPLICATION			DO NOT SCALE DRAWING			
USED ON			00002173			
DATE			1/1			