

REV	DATE	DESCRIPTION	BY	APP'D
1	11/12/12	INITIAL RELEASE		

- NOTES: UNLESS OTHERWISE SPECIFIED
- INTERPRET DRAWING IAW THE GLOBAL PROFESSIONAL PUBLICATIONS "DRAWING REQUIREMENTS MANUAL", EIGHTH EDITION.
 - INTERPRET DIMENSIONS AND TOLERANCES IAW ANSI Y14.5M - 1982.
 - INTERPRET ABBREVIATIONS IAW MIL-STD-12.
 - METRIC DIMENSIONS NOTED IN BRACKETS [].
 - GAS FITTING (INCLUDED), SWAGelok (ITEM 13) IS AVAILABLE FROM: HTTP://WWW.SWAGELOK.COM
 - MINIMUM 60" LONG POLYETHYLENE LINES REQUIRED FOR SAFE OPERATION. USER MUST SUPPLY ADDITIONAL 42" LONG POLYETHYLENE WATER LINES TO MEET THIS REQUIREMENT. DO NOT SUBSTITUTE METAL WATER FITTINGS FOR ITEM 12.
 - WATER LINE CONNECTORS (INCLUDED, ITEM 12) ARE AVAILABLE FROM: HTTP://WWW.JOHNGUEST.COM
 - MINIMUM 36" LONG TEFLON PFA LINE REQUIRED (36" INCLUDED WITH SOURCE) FOR SAFE OPERATION. DO NOT USE METAL GAS LINES TO MEET THIS REQUIREMENT - ELECTRICAL ISOLATION IS NECESSARY.
 - SEE MATERIALS SCIENCE, INC. DOCUMENT 251011 FOR PROPER INSTALLATION, OPERATION AND USED OF POLARIS SPUTTERING SOURCES.
 - MASS OF SPUTTERING SOURCE FULLY ASSEMBLED IS 5.8 LBS DRY.

DASH NO	DIM "A"
-1	12"
-2	18"
-3	24"

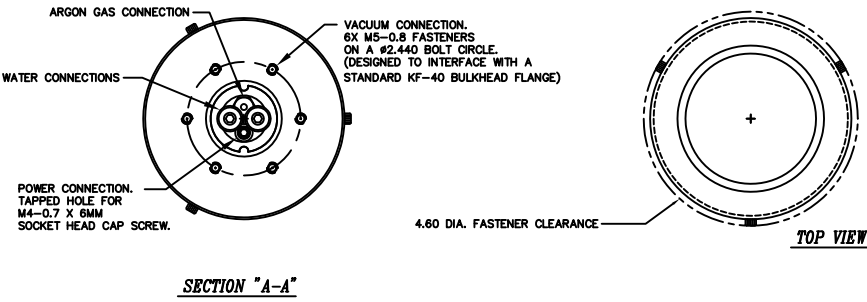
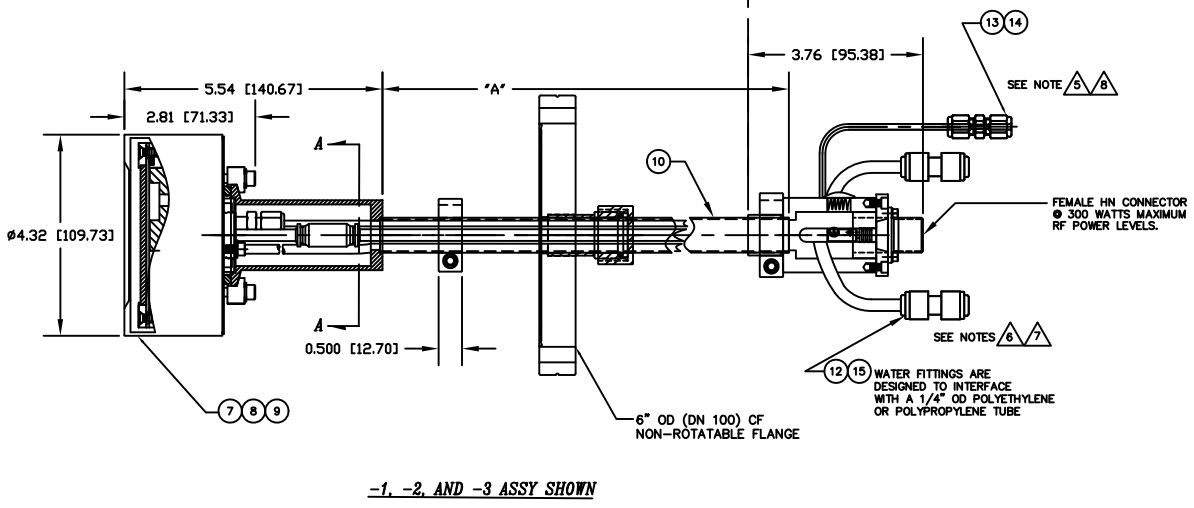
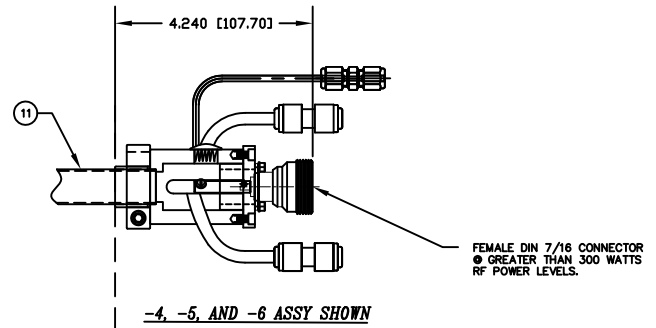

QTY	UNIT	DESCRIPTION	MATERIAL	ZONE	ITEM NO					
1	1	1	1	1	1	00000074-1	TUBING, 1/4" OD X .170" ID X 18"	POLYETHYLENE	15	
1	1	1	1	1	1	6	00000038-1	TUBING, 1/8" OD X 1/16" ID X 36" MINIMUM	TEFLON PFA	14
1	1	1	1	1	1	6	000000316	FITTING, SWAGelok, SS-200-6	316 CRES	13
2	2	2	2	2	2		00000281-1	1/4 INCH OD COUPLING, QUICK CONNECT	P/N C1040BW	12
1	1	1					00002509-2	3/4 INCH TUBE FEEDTHROUGH ASSEMBLY-DIN 7/16		11
			1	1	1		00002509-1	3/4 INCH TUBE FEEDTHROUGH ASSEMBLY-HN		10
			1				00002085-3	3 INCH INTERNAL CATHODE (CLAMPED TARGET)		9
				1			00002085-2	3 INCH INT CATHODE (DIRECT WATER COOLED TGT)		8
					1		00002085-1	3 INCH INTERNAL CATHODE (BONDED TARGET)		7
							00002508-6	3" POLARIS SOURCE, 3/4" OD TUBE FEEDTHRU ASSY		6
							00002508-5	3" POLARIS SOURCE, 3/4" OD TUBE FEEDTHRU ASSY		5
							00002508-4	3" POLARIS SOURCE, 3/4" OD TUBE FEEDTHRU ASSY		4
							00002508-3	3" POLARIS SOURCE, 3/4" OD TUBE FEEDTHRU ASSY		3
							00002508-2	3" POLARIS SOURCE, 3/4" OD TUBE FEEDTHRU ASSY		2
							00002508-1	3" POLARIS SOURCE, 3/4" OD TUBE FEEDTHRU ASSY		1

INSTALLATION CONTROL DRAWING

QUANTITY FOR ASSEMBLY	CASE CODE	PART OR IDENTIFYING NO.	NOMENCLATURE OR DESCRIPTION	MATERIAL SPECIFICATION	ZONE	ITEM NO									
	-2	-1													
PARTS LIST															
<table border="0"> <tr> <td>DATE: 11/18/12</td> <td>BY: J. MILLER</td> <td>REV: 1/18/12</td> </tr> <tr> <td colspan="3">MATERIALS SCIENCE, INC. Vacuum and Thin Film Technology</td> </tr> <tr> <td colspan="3">3 INCH POLARIS, 3/4" OD TUBE RF/DC FEEDTHROUGH ASSY</td> </tr> </table>							DATE: 11/18/12	BY: J. MILLER	REV: 1/18/12	MATERIALS SCIENCE, INC. Vacuum and Thin Film Technology			3 INCH POLARIS, 3/4" OD TUBE RF/DC FEEDTHROUGH ASSY		
DATE: 11/18/12	BY: J. MILLER	REV: 1/18/12													
MATERIALS SCIENCE, INC. Vacuum and Thin Film Technology															
3 INCH POLARIS, 3/4" OD TUBE RF/DC FEEDTHROUGH ASSY															
NEXT ASSEMBLY	USED ON	DATE	REV	DATE	REV	DATE									
APPLICATION: DO NOT SCALE DRAWING															