

REV	DATE	DESCRIPTION	BY	APP'D
INITIAL RELEASE	141111			

- NOTES: UNLESS OTHERWISE SPECIFIED
- INTERPRET DRAWING IAW THE GLOBAL PROFESSIONAL PUBLICATIONS "DRAWING REQUIREMENTS MANUAL", EIGHTH EDITION.
 - INTERPRET DIMENSIONS AND TOLERANCES IAW ANSI Y14.5M - 1982.
 - INTERPRET ABBREVIATIONS IAW MIL-STD-12.

- SEE MATERIALS SCIENCE, INC. DOCUMENT NO. 251092 FOR PROPER INSTALLATION, OPERATION AND USE OF POLARIS SPUTTERING SOURCES.
- DIFFERENT TUBE LENGTHS CAN BE SUPPLIED ACCORDING TO CUSTOMER NEED.
- WATER LINE CONNECTORS (INCLUDED, ITEM 18) ARE AVAILABLE FROM: [HTTP://WWW.JOHNQUEST.COM](http://www.johnguest.com). P/N C10408W.

- WARNING: WATER FITTINGS HAVE A CLEAR ID OF .170". USING A SLEEVE OR OTHER DEVICE INSIDE THE WATER TUBING MAY CAUSE FLOW RESTRICTIONS AND INTERFERENCE WITH THE NORMAL OPERATION OF THE SPUTTERING SOURCE AND IS THEREFORE NOT RECOMMENDED.
- WATER CHANNELS ARE SYMMETRICAL THROUGHOUT. ORIENTATION OF THE INLET AND OUTLET IS NOT CRITICAL.
- MINIMUM 60" LONG POLYETHYLENE LINES REQUIRED TO ENSURE 50 KOHM RESISTIVITY AND SAFE OPERATION. TEST USING AN OHM METER OR OTHER SUITABLE DEVICE BEFORE USE. DO NOT USE METAL TUBING! POLYETHYLENE RECOMMENDED.
- MINIMUM 36" LONG TEFLON PFA LINE REQUIRED (36" INCLUDED WITH SOURCE) FOR SAFE OPERATION. DO NOT USE METAL GAS LINES TO MEET THIS REQUIREMENT - ELECTRICAL ISOLATION IS NECESSARY.
- SWAGelok UNION FITTING, 1/8" OD TUBE IS SUPPLIED WITH SOURCE AND ALSO AVAILABLE FROM SWAGelok COMPANY [HTTP://WWW.SWAGelok.COM](http://www.swagelok.com) SWAGelok P/N SS-200-6 SWAGelok FITTING, 1/8" OD TUBE IS WELDED TO UTILITY CONNECTION MODULE.
- TUBING, TEFLON, PFA IS AVAILABLE FROM: MC MASTER CARR [HTTP://WWW.MCMASTER.COM](http://www.mcmaster.com) MCMASTER-CARR P/N 5180K51 DO NOT USE METAL GAS LINES TO MEET THIS REQUIREMENT - ELECTRICAL ISOLATION IS NECESSARY.
- WATER LINE TUBE UNION IS AVAILABLE FROM: ALPHA TECHNOLOGIES [HTTP://WWW.ALPHA FITTINGS.COM](http://www.alpha fittings.com) ALPHA PART NUMBER 88040-04
- 1/2" OD WATER TUBES AND PUSH-TO-CONNECT UNIONS HAVE BEEN REPLACED WITH 1/4" OD WATER LINES TO FIT WITHIN .75" OD TUBE FOR LOWER POWER APPLICATIONS OR WHEN ONLY 1" BASEPLATE FEEDTHROUGHS ARE PRESENT. USE OF SUCH SMALL FEEDTHROUGHS IS DISCOURAGED. CONTACT FACTORY.
- MATERIALS SCIENCE P/N 00000680 SPANNER WRENCH REQUIRED TO TIGHTEN NUT. FEDERAL SPEC GGG-W-6656. ADJUSTABLE UP TO 2". OVERALL LENGTH 6 3/8". PIN DIAMETER 3/16". PIN HEIGHT: 1/8"
- MULTI-CONTACT-USA [HTTP://WWW.MULTI-CONTACT-USA.COM](http://www.multi-contact-usa.com) P/N 05.0201 LOCKING PLUG IS SUPPLIED WITH SOURCE
- TAKE CARE NOT TO DING, SCRATCH OR GOUGE POLISHED SURFACE.

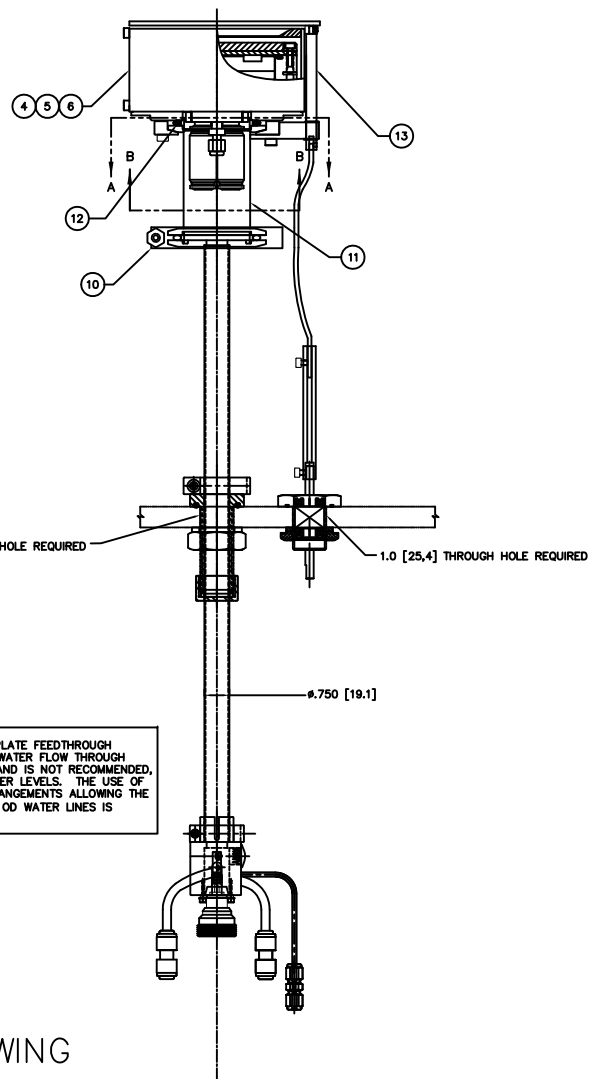

NOTE: USE OF A 1" BASEPLATE FEEDTHROUGH SIGNIFICANTLY LIMITS THE WATER FLOW THROUGH THE SPUTTERING SOURCE AND IS NOT RECOMMENDED, EXCEPT AT VERY LOW POWER LEVELS. THE USE OF BIGGER FEEDTHROUGH ARRANGEMENTS ALLOWING THE USE OF 3/8" OD OR 1/2" OD WATER LINES IS STRONGLY RECOMMENDED.

INSTALLATION CONTROL DRAWING

QTY	REV	DESCRIPTION	MATERIAL	ZONE	ITEM NO	
2	2	2	00000074-1	TUBING, 1/4" OD X 3/8" ID X 18" LONG	POLYETHYLENE	18
2	2	2	0000281-1	1/4" OD COUPLING, QUICK DISCONNECT	POLYPROPYLENE	17
1	1	1	00002132	FEEDTHROUGH, ROTARY, FERROFLUID SEAL		16
1	1	1	00002133	FEEDTHROUGH SHAFT CABLE CONNECTOR	304 CRES	15
1	1	1	00002134	FLEXIBLE CABLE ASSEMBLY	304 CRES	14
1	1	1	00002490	SHUTTER ASSEMBLY, 4 INCH SUNSOURCE	304 CRES	13
1	1	1	00000100-4	CENTERING RING, KF-50		12
1	1	1	00002489	NIPPLE, KF-50 X 3.29 LONG	316 CRES	11
1	1	1	00000099	SWING CLAMP, KF-40	304 CRES	10
1	1	1	00000038-1	TUBING, 1/8" OD X 1/16" ID X 36" MINIMUM	TEFLON PFA	9
1	1	1	00000316	UNION, SWAGelok, SS-200-6	316 CRES	8
1	1	1	00002606	3/4" OD INCH TUBE FEEDTHROUGH ASSEMBLY	304 CRES	7
1			00001026-3	4 INCH INTERNAL CATHODE (CLAMPED TARGET)		6
1			00001026-2	4 INCH INT CATHODE (DIRECT WATER COOLED TGT)		5
1			00001026-1	4 INCH INTERNAL CATHODE (BONDED TARGET)		4
			00002852-3	4" SUNSOURCE, VARIABLE POSITION & SHUTTER		3
			00002852-2	4" SUNSOURCE, VARIABLE POSITION & SHUTTER		2
			00002852-1	4" SUNSOURCE, VARIABLE POSITION & SHUTTER		1

QUALITY FOR ASSEMBLY	DATE	BY	APPROVED
	10/11/11	J. MILLER	
NEXT ASSEMBLY	USED ON	DO NOT SCALE DRAWING	
APPLICATION			

MATERIALS SCIENCE, INC.
 Vacuum and Thin Film Technology
 4" INTERNAL, VARIABLE POSITION & SHUTTER -1" B.P. F/THRU
 00002852
 1/1

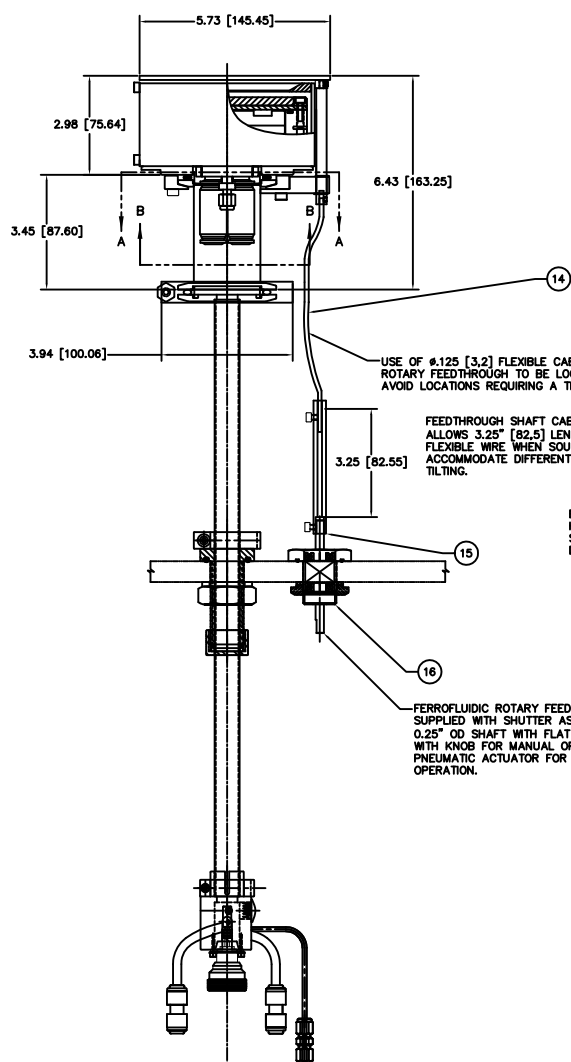

USE OF ϕ .125 [3.2] FLEXIBLE CABLE ASSEMBLY ALLOWS ROTARY FEEDTHROUGH TO BE LOCATED WHERE CONVENIENT. AVOID LOCATIONS REQUIRING A TIGHT BEND RADIUS.

FEEDTHROUGH SHAFT CABLE CONNECTOR ALLOWS 3.25" [82.5] LENGTH ADJUSTMENT OF FLEXIBLE WIRE WHEN SOURCE IS TILTED TO ACCOMMODATE DIFFERENT LENGTH CAUSED BY TILTING.

ENTIRE OUTSIDE OF TUBE HAS 32 RMS FINISH - DO NOT SCRATCH, DING OR OTHERWISE DAMAGE SURFACE. SEE NOTE 14

FERROFLUIDIC ROTARY FEEDTHROUGH SUPPLIED WITH SHUTTER ASSEMBLY, 0.25" OD SHAFT WITH FLAT INTERFACES WITH KNOB FOR MANUAL OPERATION OR PNEUMATIC ACTUATOR FOR AUTOMATIC OPERATION.

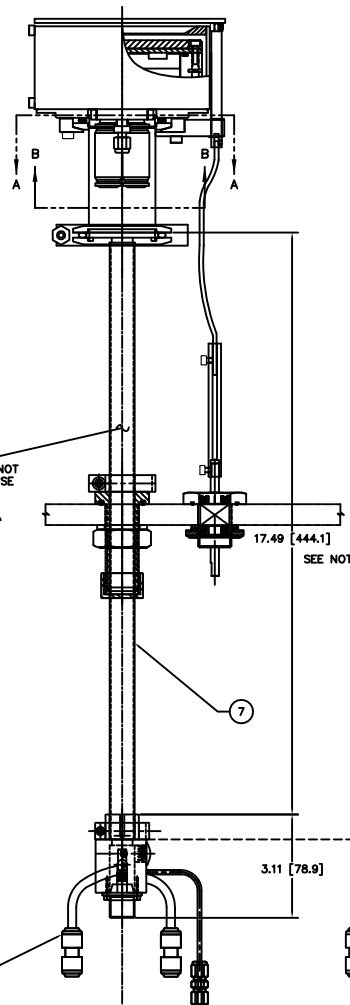

SEE NOTE 16

0.540 [13.72]
 0.535 [13.59]

SEE NOTE 14
 LOCKING SOCKET P/N 00000712 SOCKET SCREWS INTO M6 X 10 DEEP TAPPED HOLE. SOLDER CUP DIMS ON MATING PLUG FOR POWER CABLE CONNECTION = 5MM DIAMETER X 14M DEEP BORE

SEE NOTES 14, 15, 16, 17, 18
 2X PUSH-TO-CONNECT WATER FITTINGS (INCLUDED) ARE DESIGNED TO INTERFACE WITH A .25" OD POLYETHYLENE TUBE

8X M5-0.8 FASTENERS ON A ϕ 3.250 BOLT CIRCLE. (DESIGNED TO INTERFACE WITH A STANDARD KF-50 BULKHEAD FLANGE)

SWAGelok FITTING FOR ARGON GAS CONNECTS TO 1/8" OD X 36" LG (MINIMUM) TEFLON PFA TUBING
 SEE NOTES 14, 15, 16, 17, 18

ϕ 5.600 [142.24] FASTENER CLEARANCE

SECTION B-B

SECTION A-A

17 18 WATER FITTINGS ARE DESIGNED TO INTERFACE WITH A 1/4" OD POLYETHYLENE OR POLYPROPYLENE TUBE
 SEE NOTES 6, 17

SEE NOTE 7/8

FEMALE DIN 7/16 CONNECTOR ϕ GREATER THAN 300 WATTS RF POWER LEVELS.

FEMALE HN CONNECTOR ϕ 300 WATTS MAXIMUM RF POWER LEVELS.

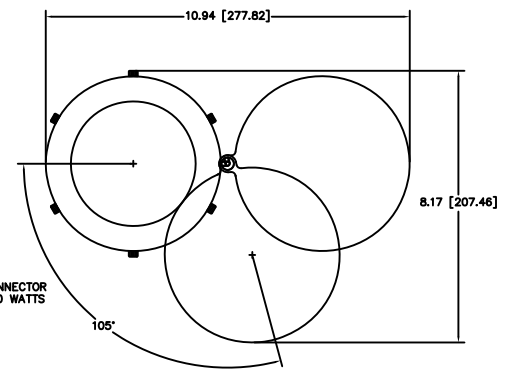

MINIMUM SHUTTER SWING CLEARANCE