

REV	DATE	BY	APP'D
INITIAL RELEASE	150810	J. MILLER	

- NOTES: UNLESS OTHERWISE SPECIFIED
- INTERPRET DRAWING IAW THE GLOBAL PROFESSIONAL PUBLICATIONS "DRAWING REQUIREMENTS MANUAL", EIGHTH EDITION.
  - INTERPRET DIMENSIONS AND TOLERANCES IAW ANSI Y14.5M - 1982.
  - INTERPRET ABBREVIATIONS IAW MIL-STD-12.

**4** WARNING: WATER FITTINGS HAVE A CLEAR ID OF .25 INCHES. USING A SLEEVE OR SIMILAR DEVICE INSIDE THE WATER HOSE MAY CAUSE FLUID RESTRICTIONS AND INTERFERENCE WITH THE NORMAL OPERATION OF THE CATHODE AND THEREFORE IS NOT RECOMMENDED.

**5** WATER CHANNELS ARE SYMMETRICAL THROUGHOUT. ORIENTATION OF WATER INLET OR OUTLET IS NOT CRITICAL.

**6** WARNING: MINIMUM HOSE LENGTH OF 60" IS REQUIRED TO ENSURE RESISTIVITY RELATIVE TO ELECTRICAL GROUND WITHIN 50 KILO OHMS. TEST CABLE WITH AN OHM METER OR OTHER SUITABLE DEVICE BEFORE USE. DO NOT USE METAL TUBING! POLYETHYLENE RECOMMENDED.

**7** SWAGELOCK UNION FITTING, 1/8" OD TUBE IS SUPPLIED WITH SOURCE AND ALSO AVAILABLE FROM SWAGELOK COMPANY HTTP://WWW.SWAGELOK.COM OR SAN DIEGO FLUID SYSTEM TECHNOLOGIES 6350 NANCY RIDGE DRIVE, SUITE 101 SAN DIEGO, CA 92121 (658) 320-4000 SWAGELOK P/N SS-200-6

SWAGELOCK FITTING, 1/8" OD TUBE IS WELDED TO UTILITY CONNECTION MODULE.

**8** TUBING, TEFLON, PFA IS AVAILABLE FROM: MC MASTER CARR 9630 NORWALK BLVD SANTA FE SPRINGS, CA 90670-2932 VOICE: (310) 692-5911 FAX: (310) 695-2323 MCMASTER-CARR P/N 5180K51

**9** WATER LINE TUBE UNION, IS AVAILABLE FROM: ALPHA TECHNOLOGIES 320 PREMIER COURT, SUITE 222 FRANKLIN, TN 37067 TEL: (615) 771-8650 ALPHA PART NUMBER 88040-06

10. SEE MATERIALS SCIENCE, INC. DOCUMENT NO. 251092 FOR PROPER INSTALLATION, OPERATION AND USE OF SUNSOURCE SPUTTERING SOURCES.

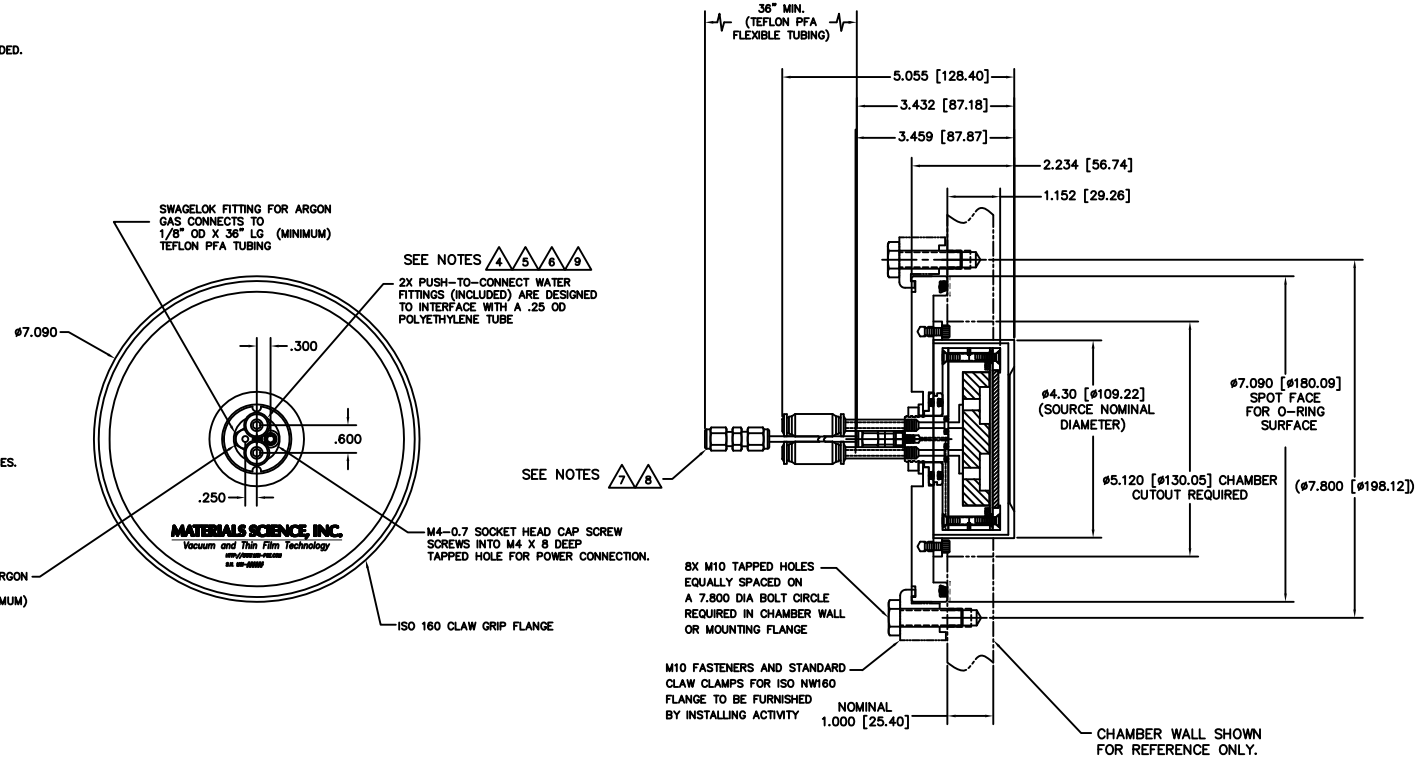

INSTALLATION CONTROL DRAWING

QTY	CODE	PART OR IDENTIFYING NO.	NOMENCLATURE OR DESCRIPTION	MATERIAL SPECIFICATION	ZONE	ITEM NO.
			PARTS LIST			
			DATE: J. MILLER 06/08/10			
			MATERIALS SCIENCE, INC.			
			POLARIS, 3 INCH FLANGE MOUNT, INSTALLATION CONTROL			
						00002879
						1/1
						1

00002879