

BONDED TARGET ASSEMBLIES

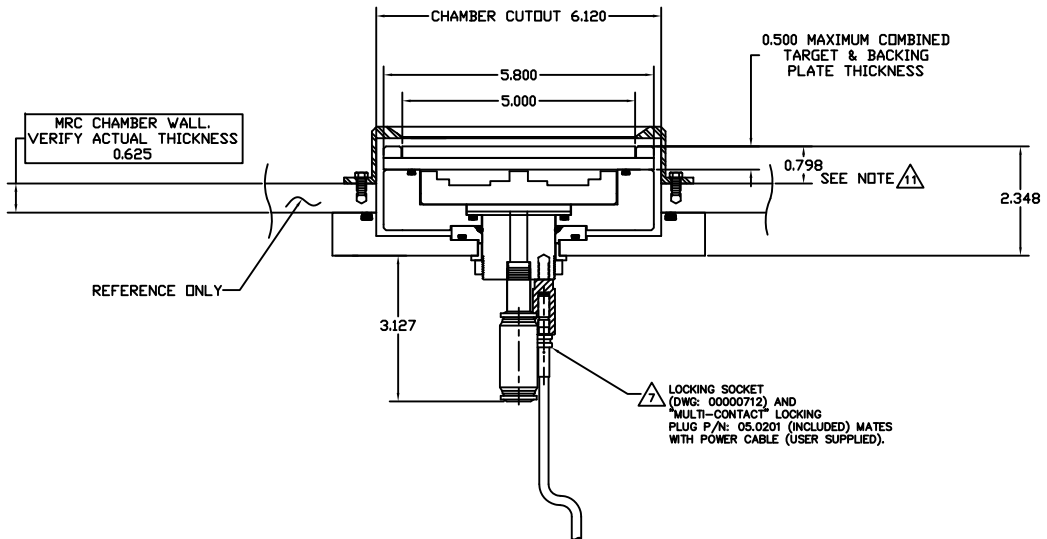

SECTION B-B

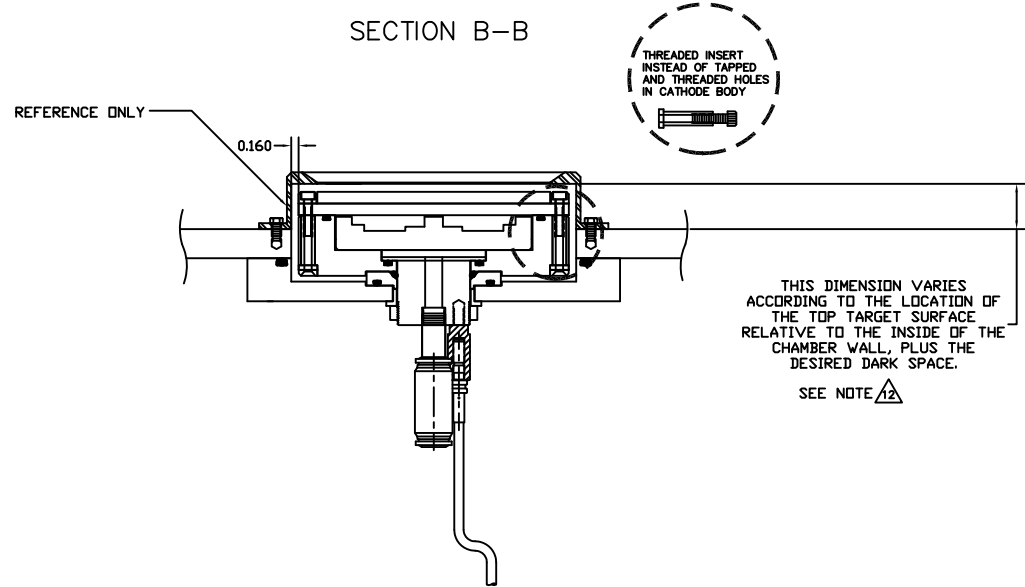

SECTION A-A

8 7 6 5 4 3 2 1

REV		DESCRIPTION	DATE	APP'D
1		SEE SHEET 1		

DIRECTLY WATER COOLED FOR NICKEL TARGETS

MECHANISM FOR INSTALLING AND REMOVING MAGNETIC TARGETS IS PROVIDED, BUT NOT SHOWN.

0.200 TARGET THICKNESS

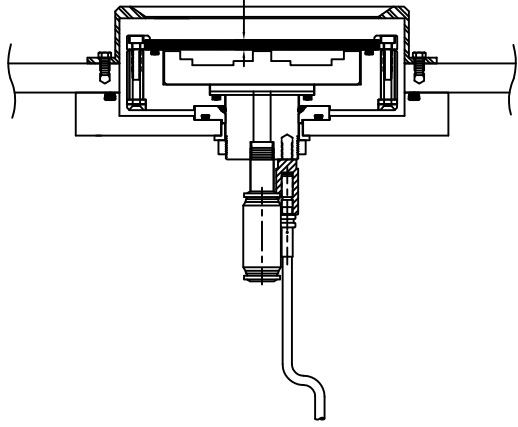

H
G
F
E
D
C
B
A

H
G
F
E
D
C
B
A

8 7 6 5 4 3 2 1

E	1/1	00002986	3
---	-----	----------	---

00002986