

NOTES: UNLESS OTHERWISE SPECIFIED

1. INTERPRET DRAWING IAW THE GLOBAL PROFESSIONAL PUBLICATIONS "DRAWING REQUIREMENTS MANUAL", EIGHTH EDITION.
2. INTERPRET DIMENSIONS AND TOLERANCES IAW ANSI Y14.5M - 1982.
3. BREAK SHARP EDGES .002--015.
4. INTERPRET ABBREVIATIONS IAW MIL-STD-12.
5. DIMENSIONS IN BRACKETS "[ ]" DENOTE REFERENCE DIMENSIONS IN MILLIMETERS.
6. FOR FURTHER FABRICATION REQUIREMENTS, SEE MATERIALS SCIENCE, INC. SPECIFICATION NO. 10000000.

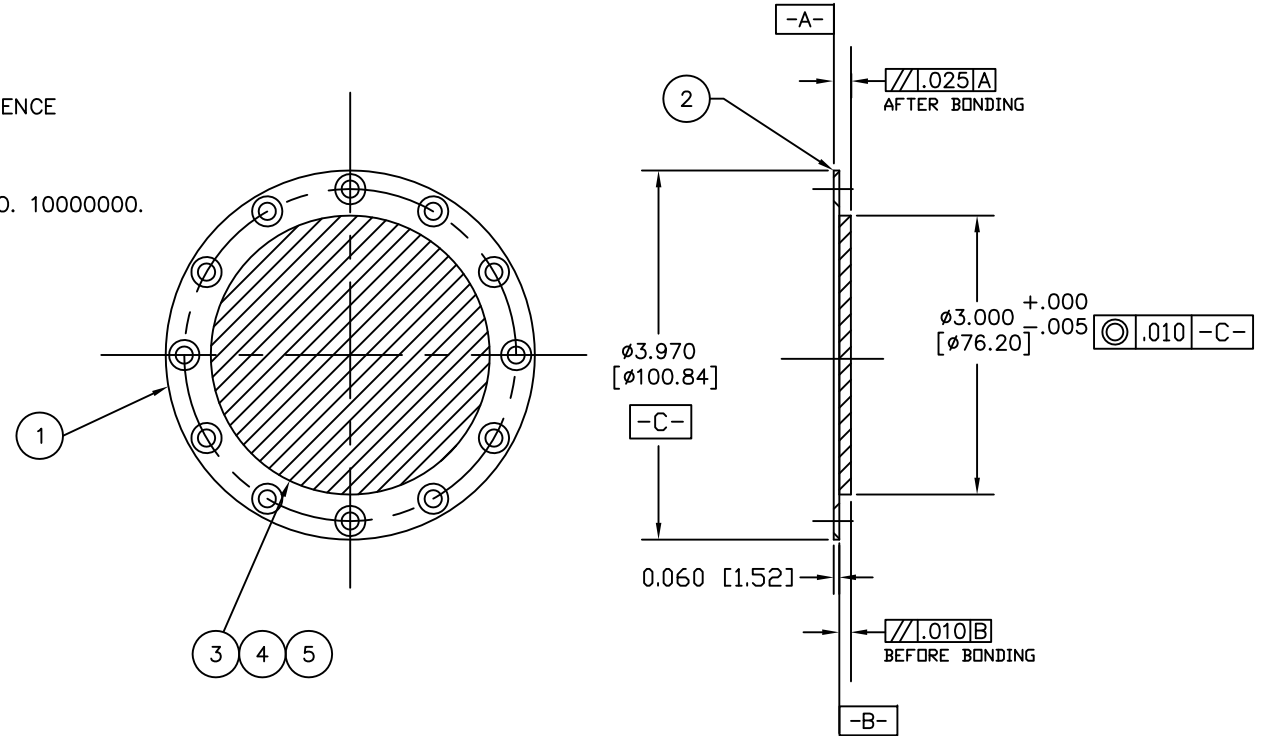

QUANTITY PER ASSEMBLY	CAGE CODE	PART OR IDENTIFYING NO.	NOMENCLATURE OR DESCRIPTION	MATERIAL SPECIFICATION	ZONE	ITEM NO.
1		00000709-3	TARGET, 1/4" THICK			5
1		00000709-2	TARGET, 3/16" THICK			4
1		00000709-1	TARGET, 1/8" THICK			3
1	1	1	00002091-X	BACKING PLATE		2
		1	00002092	BONDED TARGET ASSY, 3" DIA.		1
-3	-2	-1				

APPLICATION		DO NOT SCALE DRAWING		SCALE 1/1		SHEET 1 OF 1	
NEXT ASSEMBLY	USED ON	FINISH	APPROVAL	DATE	DWG. NO.	REV	
			J. MILLER	10/09/13	00002092	-	
<small>UNLESS OTHERWISE SPECIFIED DIMENSIONS ARE IN INCHES TOLERANCES ARE: DECIMALS ANGLES</small> <small>F ±.030 ±0.50°</small> <small>M ±.010 ±0.25°</small> <small>XX ±.005 ±0.125°</small>				<small>THE BUYER'S SPECIAL PROPERTY REQUIREMENTS FOR THIS DRAWING SHALL TAKE PRECEDENCE OVER ANY OTHER REQUIREMENTS UNLESS OTHERWISE SPECIFIED</small>			
<small>MACHINE SURFACES UNLESS OTHERWISE SPECIFIED</small>				<b>MATERIALS SCIENCE, INC.</b> <small>Vacuum and Thin Film Technology</small> <small>msc@msinc.com</small>			
<small>THE BUYER'S SPECIAL PROPERTY REQUIREMENTS FOR THIS DRAWING SHALL TAKE PRECEDENCE OVER ANY OTHER REQUIREMENTS UNLESS OTHERWISE SPECIFIED</small>				<b>BONDED TARGET ASSY, 3 INCH DIAMETER, METRIC</b>			

Dwg No. 00002092