

MATERIALS SCIENCE, INC.

Vacuum & Thin Film Technology

SunSource™ GEN II Linear Magnetron Sputtering Sources



>90mm Wide
>High Target Utilization
>No Center Redeposition



Key Features and Benefits

- KamLok™ (US Patent Pending) Fast Target Exchange System eliminates galling & seizure of fasteners. Exchange targets in minutes regardless of length – even when still installed in system.
- Wide Uniform Erosion Area results in stable operation, minimal distribution & uniformity/rate changes throughout the target lifetime.



Single Feedthrough Internal Mount

- 20% Higher rates due to broad erosion area & highly efficient cooling.
- Active Plasma Discharge on nearly entire target surface keeps target clean & reduces insulating film growth that leads to arcing.
- Power Levels Can Exceed 500 watts/in² for Directly Water Cooled Targets.
- 35-45 wt% Real Target Utilization (Useful Target Life used in practical situations & applications – not artificial definitions or strained examples).
- Low 10-4 Torr Range Operation.
- Argon Gas Through Cathode Body – Additional Feedthroughs, external manifolds & other plasma disturbing hardware that increases required periodic maintenance frequency is unnecessary.
- Uniform Target Erosion and Distribution.
- Internal and Flange Mount Versions in multiple installation configurations.
- Can be Used in DC, Pulsed DC, AC, RF & HIPMS Modes.
- 90mm, 3.5" & 6" Wide Targets Standard.
- "Unbalanced" Magnet Modules Can Be Supplied as Opposing Pairs for for Single Source.

[Here are a few reasons why Experienced Users will immediately understand why SunSource GEN II™ Sources are so much better than competing designs:](#)

No profiled magnet arrays with intense magnetic fields that extend well into the chamber and behind the target. These designs cause arcing and sputtering of the source and adjacent hardware unless very precise dark space gaps are maintained at specific pressures. Pressure changes cause the problem to re-occur.

The well-confined primary magnetic fields of SunSource GEN II™ do not interfere with or influence adjacent sputtering, ion or plasma sources. This can result in arcing, huge differences in target erosion rates/depth along the length and premature target burn-through.

The exit water flow through the cathode body is the same as the inlet flow. There are no internal water flow restrictions or backpressure. The result is higher achievable power levels, uniform target cooling mitigating against hot spots & whisker growth & effective cooling of the magnet array for a longer lifetime.

Multiple internal gas distribution circuits can be incorporated into a single source - making balancing of pressure & gas flow in large (or just poorly designed & pumped) systems vastly easier.

The target clamps and cathode body are not sputtered. Films are not contaminated and the target clamps are not a consumable item.

The KamLok™ Fast Target Exchange System completely eliminates downtime and service costs associated with fasteners that have galled & seized after exposure to high temperature, vacuum & re-deposited material. Targets of any length can be very quickly installed & replaced - in minutes rather than hours.

The robust, rugged design of SunSource GEN II™ sources makes the cost of ownership much lower. All external insulators have been eliminated & the implementation of the Utility Module makes leaky brazed or soldered water lines a thing of the past. Locking push-to-connect water and electrical fittings ensure absolutely reliable, easy to service utility connections.

Anode/Ground Shields are easily removed for service & cleaning. They are thick wall stainless steel to withstand repeated exposure to vapor honing, grit blasting & chemical cleaning. We never machine the source & mounting flange from a single piece of aluminum. We never weld the anode/ground shields together - they crack due to thermal expansion during use and in both cases, the entire source has to be removed and disassembled for routine maintenance.

Use of high quality, structurally strong, high dielectric value Ultem insulator material instead of cheap Delrin that turns to carbon when an arc occurs & Teflon that cold flows and leaks over time.

Zinc plated magnets exposed to vacuum used in competing designs are not used.

Practical Innovations That Save Money and Increase Productivity

Explore the Difference for Yourself!

- Kamlok™ Fast Target Exchange System eliminates the use of fasteners to retain targets to sputtering source. It prevents damage to cathode body caused by galled and seized fasteners.
- Fewer parts to service and replace.
- Durable, high reliability water, power, vacuum and gas connections. Components damaged during use or maintenance can be easily replaced by the user - No machining, welding or brazing required.
- Target exchange is quick and easy - Simply remove anode/ground shields, turn small number of Kamscrews, remove target clamps, replace target and reassemble.
- External screw insulators have been eliminated.
- Reliable push-to-connect locking water and power fittings.

Flange Mount Configuration

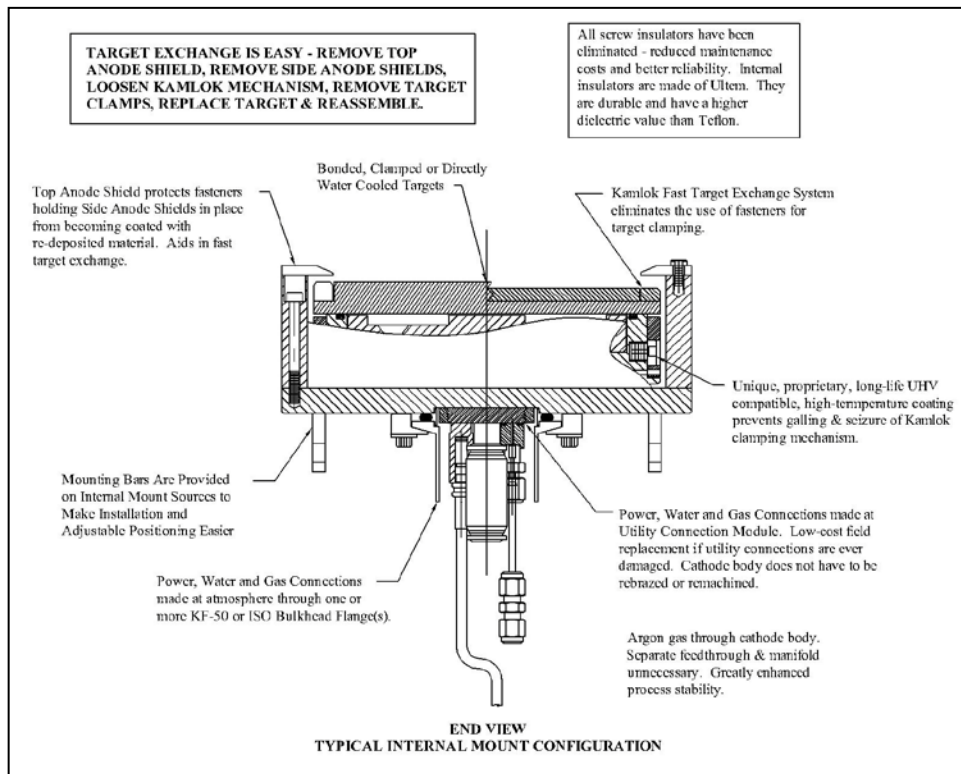

Detailed Views from Hyperlinks embedded in Illustration and Photos on Web Site

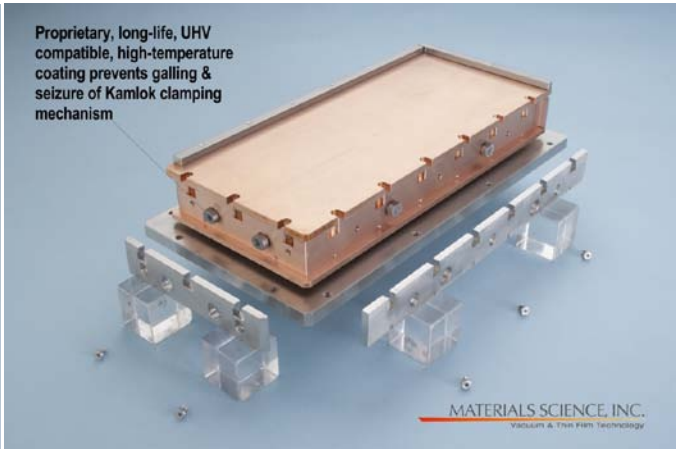
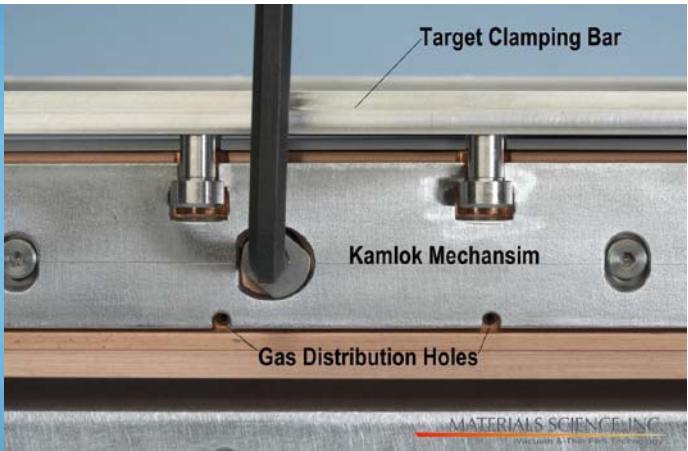

Eroded targets

Available in a Wide Variety of installation Configurations (Not Limited to the Examples Shown)

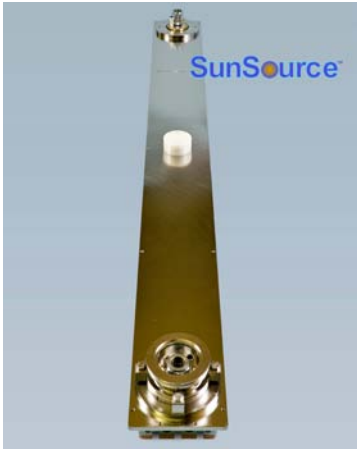

Long Internal Source - ISO Flanges

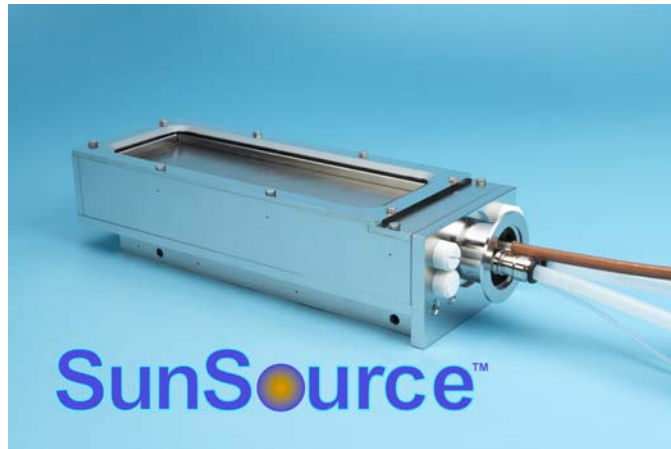

Cantilever Source

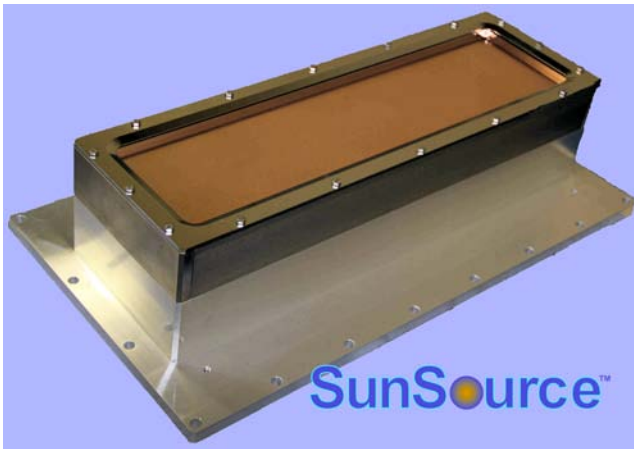

Custom Flange Mount

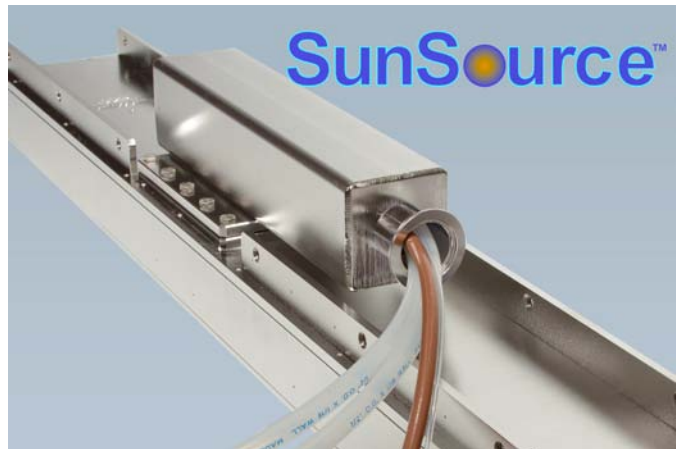

Low Profile Internal Mount with Atmospheric Utility Housing



Retrofit Sources for Legacy Sputtering Systems

Materials Science, Inc.
1662 Los Altos Road
San Diego, CA 92109
Tel: (858) 483-3223
Web site: www.msi-pse.com
E-mail: sales@msi-pse.com