

MATERIALS SCIENCE, INC.

Vacuum & Thin Film Technology



Ion™ 1500 DC Magnetron Power Supply

- Superior Arc Detection & Suppression
- Adjustable Arc Detection Delay & Off Time Before Restarting
- Voltage, Current and Power Regulation Modes
- Adjustable Power Ramping
- Adjustable Run Timer
- Stored Target Parameters for Up to 7 Separate Targets
- kWhr Counting & Time Limit
- RS-232 & Analog Communication Capability
- Wide 0-1000 Volt Range Compared to 0-800 volts Supplied by Competitors – Full Rated Power Can be Applied Under Nearly all Conditions
- Stable Operation down to 20 watts for non-reactive processes
- Suitable for use as a Substrate Bias Power Supply
- No Transformer Tap Changes Are Necessary to Operate Across Entire Range
- 2 Year Warranty ■ CE Compliant



Complete Sputtering Packages

Polaris™ GEN II 2" & 3" Research Sputtering Sources used in combination with the Ion™ 1500 allow performance not possible with any other sputtering source and DC power supply, for example:

- Sputter 1/4" [6,35 mm] thick Ni targets
- Deposit insulating films from metallic targets without the use of expensive power supplies in an essentially arc-damage free environment
- Achieve superior target utilization
- Apply virtually full rated output of power supply to source across broad pressure range
- Deposit very thin films at extremely low power levels

Arc Damage is Virtually Eliminated When Arc Detection & Suppression is Activated

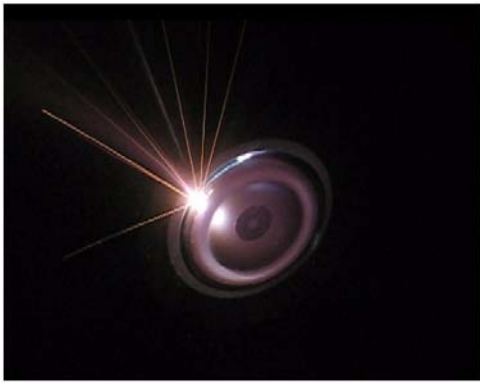

Hard arc on Al target in O₂ environment on 3" Polaris™ source - no arc suppression



Same view & conditions as at left, but with plasma re-igniting - arcing is still decaying



Arc suppression of Ion™ 1500 working in same environment & conditions - producing a stable plasma & good target utilization with negligible arc induced damage

Specifications

Description	Value
Input Frequency	50 - 60 Hz
Input Phase	1 phase
Input Voltage	85 - 275 VAC (lower VAC may limit output)
Input Current	12.5 amps maximum
Power Factor	> 0.98
Input Power Consumption	1.75 kW
Output Power	1500 watts
Output Power @ 1000 volts	1500 watts
Output Power @ 500 volts	1500 watts
Output Power @ 200 volts	800 watts
Output Voltage (steady state)	1000 volts maximum
Output Voltage (strike)	1000 volts maximum
Output Current (maximum)	4 A
Arc Detection Time	< 100 nsecs (.1 μ secs)
Arc Energy	< 1 mJ
Arc Detect Delay Time	0.1 to 6500 μ secs (adjustable)
Arc Out/Off Time	0 (no arcing handling) or 32 to 65000 μ secs (adjustable)
Arc Rate Counter	Yes
Arc Recovery Time	Set points will be re-established < 200 μ secs after arc off time
Line Regulation	> 99% (includes load and line variations over an arbitrary time interval) - aka < 1%
Load Regulation	> 99% (includes load and line variations over an arbitrary time interval) - aka < 1%
Power Ramping	0.001 to 65 seconds (adjustable)
Run Timer	0.1 to 6553 seconds (adjustable)
kWhr Counting	Yes
kWhr Limit	0 (limit shutdown disabled) or 0.01 to 655 kWhr's
LED Display Accuracy	1%
Display Resolution	0.1 watt, 1 volt, 0.001 amp (1 milliamp)
Stored Target Information	Stores parameter sets for targets that can be re-installed after exchange. Saves P/V/I, ramp time, run time, arc detect delay, arc off time, kWhr's for 7 separate targets
Interlocks	1 each
Temperature Monitoring/Protection	Yes. "Fan on Demand" cooling with thermal shutdown protection.
Dimensions	48.3 cm/19" x 47.6 cm/18.75" x 4.44 cm/1.75" (1 U Rack Height)
Weight	8.2 kG/18 pounds
RS-232/Analog Interfaces	Yes
DC Bias Operation	Basic open circuit operation between 1000 volts to < 100 volts
Output Power Connector	SO 239 (Female UHF)

Manufactured in the United States of America

Dimensions

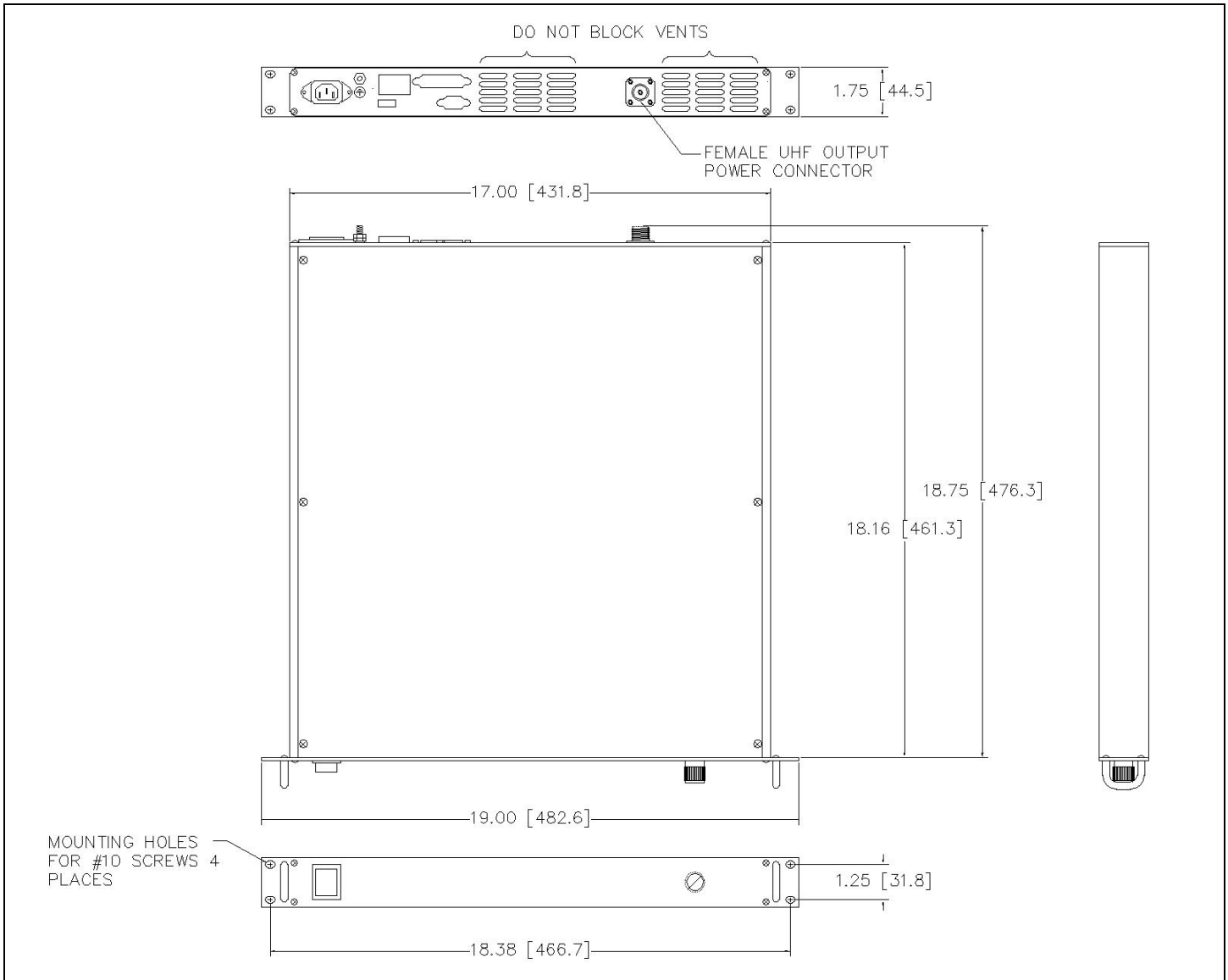

Materials Science, Inc.
1662 Los Altos Road
San Diego, CA 92109
Tel: (858) 483-3223
E-mail: sales@msi-pse.com